



# INDUSTRIAL BRAKING SYSTEMS

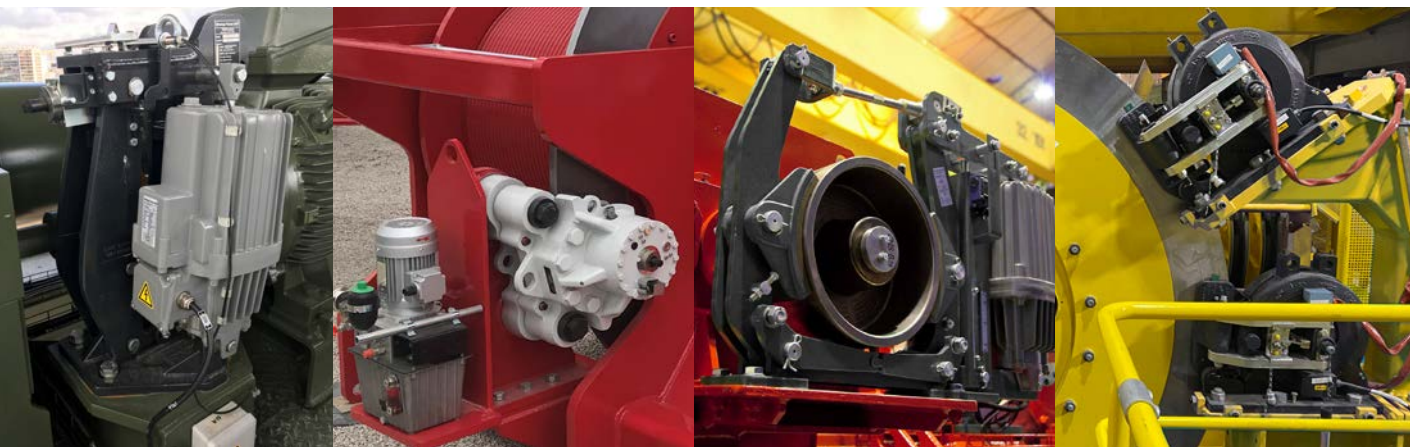
FOR CRANE APPLICATIONS



# OUR COMPANY

**Stromag is a global supplier of braking packed solutions for crane market.**

**Constant attention to evolving needs and its effort to focus its product development on quality and innovation allow our company to meet global supply requirements with standard or fully customised braking systems solutions.**



At Stromag, the accent is placed firmly upon research and innovation. That is why every year, the company invests heavily into Research and Development to provide leading edge products.

With in-depth knowledge and experience in all key applications and markets, the company keeps constantly abreast of the every changing needs and market development.

The R&D department uses unique test facilities like the braking simulation tower and many dynamic benches allowing to test the brakes under real operating conditions.

In a mutually beneficial way, Stromag creates a strong relationship with its customers in order to understand their needs and provide them the best solution. Stromag engineers and technicians are developing with its customers the brakes of tomorrow.

With more than 60 years of experience in the supply of high efficiency braking systems, Stromag provides disc brakes certified by recognised authorities such as DNV, ABS, TUV, Lloyd's Register and EDF. The certification ISO9001 of our Quality management system was renewed under the version ISO 9001 - V2015 in 2018, combined with OHSAS 18001 - V2007 certification.



# SOLUTIONS FOR YOUR APPLICATION

Stromag is particularly active in traditional areas such as steel industry, nuclear plants, port applications and mass transport as well as on fast-growing markets such as offshore applications. Stromag provides complete braking solutions to ensure the safety of many applications, such as:



## STEEL INDUSTRIES

- Service and emergency brakes
- Electromagnetic, hydraulic and thruster brakes
- Control and safety systems



*Photo courtesy of REEL*

## NUCLEAR INDUSTRIES

- Braking systems meeting all safety requirements
- Electromagnetic and hydraulic brakes
- Specific monitoring systems

## CONSTRUCTION INDUSTRIES

- Disc brakes and drum brakes
  - Soft braking
- Manual Overload Protection System MOPS



*Photo courtesy of MORITSCH*

## MARINE & OFFSHORE

- Electromagnetic and hydraulic brakes
  - Reinforced anti-corrosion protection
- Modular braking systems for high power motors



## PORTS

- High performance braking
- Disc brakes - Drum brakes - Storm brakes
- Speed monitoring systems



## MINING

- Regulated braking system in all conditions of load
- Hydraulic brakes and thruster brakes
- Deceleration control and speed regulation

# A SOLUTION FOR EACH APPLICATION

**Stromag offers an extensive range of products to secure all lifting and transmission equipments:**

- service brakes and emergency stop brakes,
- modules for monitoring overspeed, the driveline or the operation of hydraulic systems,
- and also peripheral products such as the cardan shafts or the buffers.

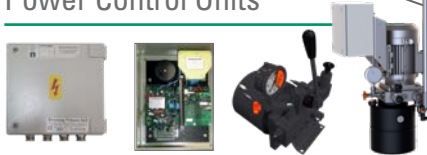
## Emergency Brakes



## Service Brakes



## Power Control Units



## SioT - Monitoring Systems



## Drums - Discs - Couplings

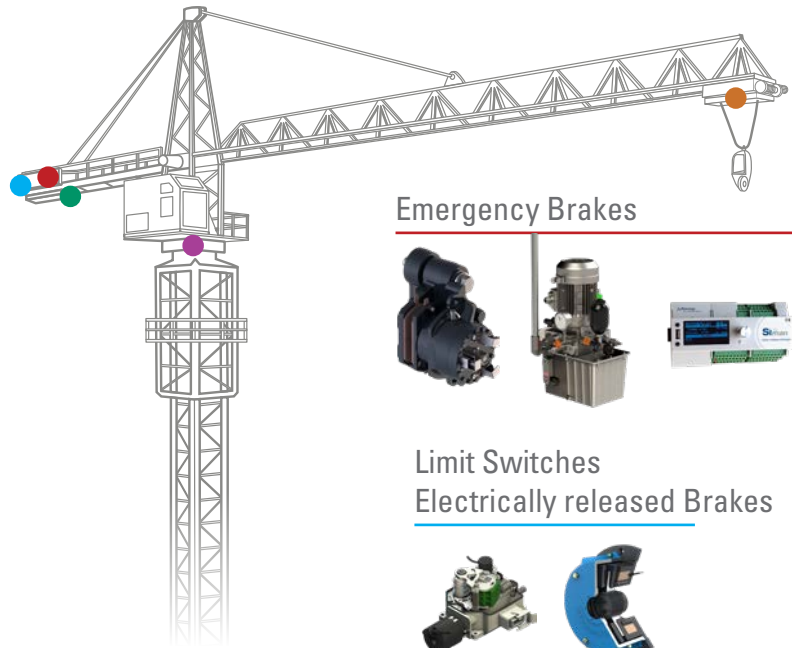


**NUCLEAR CRANES - TRAVELLING OVERHEAD CRANES - GANTRY / SEMI GANTRY CRANES**

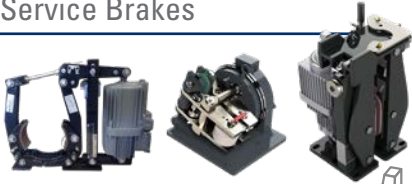


Photo courtesy of REEL





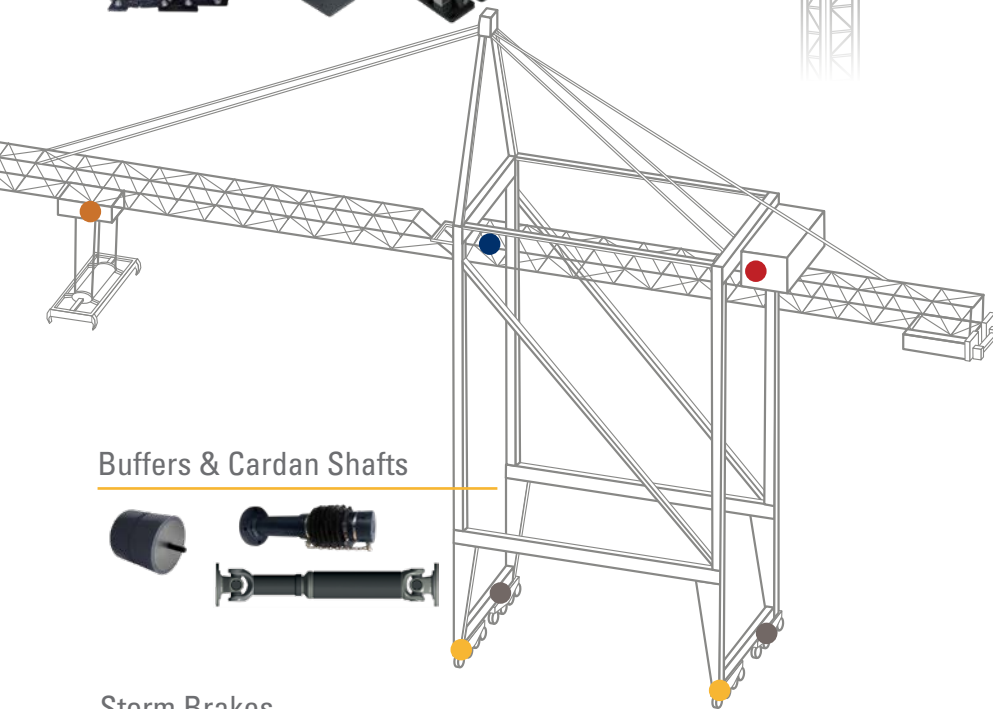
**Service Brakes**



**Emergency Brakes**



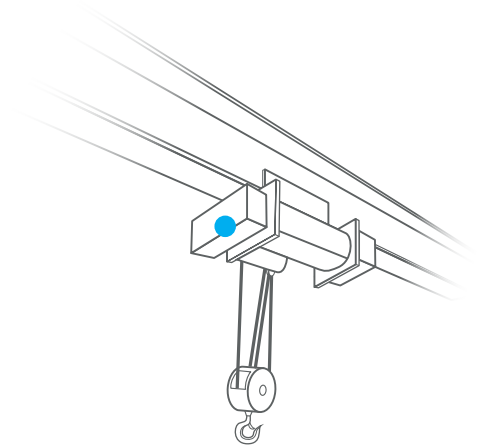
**Limit Switches  
Electrically released Brakes**



**Buffers & Cardan Shafts**



**Storm Brakes**



**Limit Switches  
Electrically released Brakes**



**PORTAL CRANES - TOWER CRANES - JIB CRANES - CHAIN AND WIRE ROPE HOISTS**



Photo courtesy of COMEDIL



Photo courtesy of COMANSA

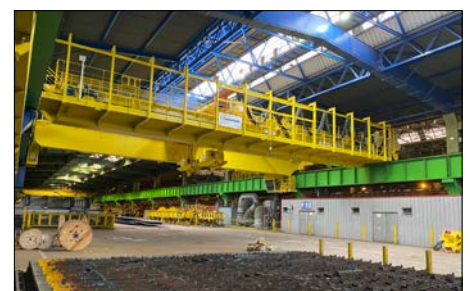


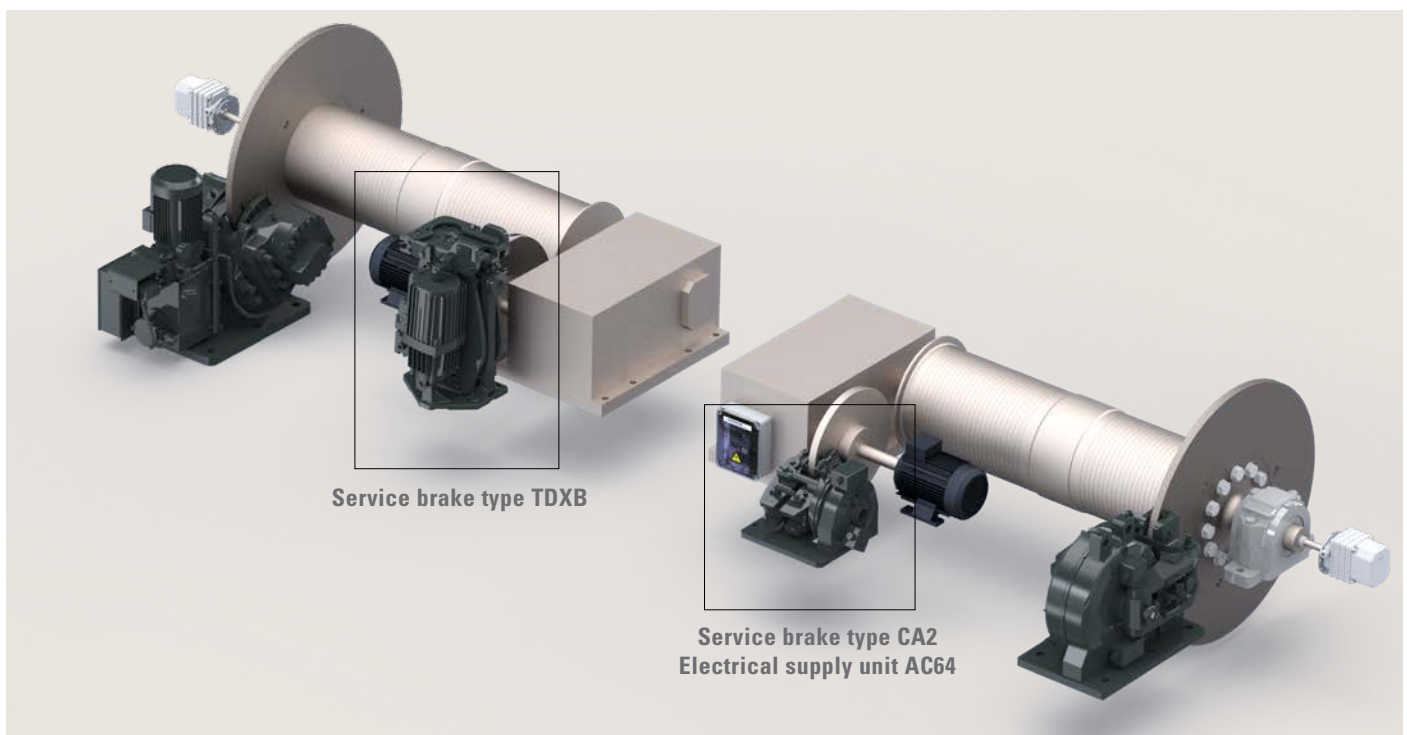
Photo courtesy of TAIM WESER



# SERVICE BRAKES

**Service brakes are installed on the high speed line of the gearbox. These brakes follow motor ratings and can be equipped with an automatic wear compensation, ensuring a constant torque whatever the wear of the lining pads. These brakes can be equipped with several options.**

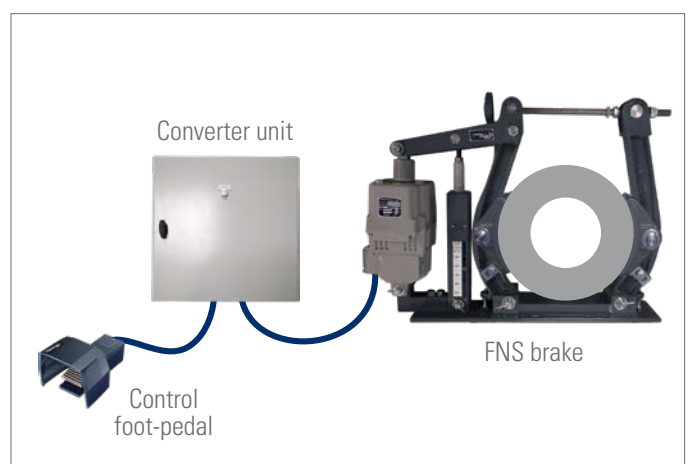
- **Electromagnetic brakes** are associated to the electrical power units AC64-FB or AC32. They are mainly used in nuclear and steelworks applications.
- **Hydraulic brakes** offer an incomparable braking torque stability.
- **Thruster brakes** are designed for high braking torque applications such as ports, iron and steel or mining.
- **Drum brakes** are used when the mechanical constraints are not an overriding factor.



## CONTROLLED BRAKING WITH THRUSTER BRAKES

For installations requiring the smooth and progressive application of the braking force, for example port cranes with drivers cabin, Stromag provide braking solutions allowing the proportional application of the braking torque by one (or two) thruster brake (drum brake or disc brake) through a converter unit:

- by action on a potentiometric control foot-pedal, or
- by control from the customer PLC: the required rate of deceleration is set on the CRD® system and the speed is monitored by the SIDEOS One module supplied by Stromag, consult us.



## ELECTROMAGNETIC BRAKES



<b>CA2 RANGE</b>
Braking torque 665 - 8040 N.m
Disc Ø445 to 995
<ul style="list-style-type: none"> <li>• High performance braking</li> <li>• All applications</li> <li>• Vertical mounting in option</li> </ul>



<b>600 RANGE</b>
Braking torque 33 - 1104 N.m
Disc Ø175 to 625
<ul style="list-style-type: none"> <li>• Economical</li> <li>• Manual wear compensation</li> </ul>



<b>K/D RANGE</b>
5K Braking torque 48 - 552 N.m
45K Braking torque 287 - 1188 N.m
Disc Ø445 to 995
<ul style="list-style-type: none"> <li>• Compact, simplicity of setting</li> <li>• Vertical mounting in option</li> </ul>

## THRUSTER BRAKES



<b>TDXB THRUSTER BRAKES</b>
Braking torque 901 - 21 240 N.m
Disc Ø315 to 995
<ul style="list-style-type: none"> <li>• Symmetrical design</li> <li>• Weight: TDXB-I: 85 kg / TDXB-II: 190 kg</li> </ul>



<b>FAV THRUSTER BRAKES</b>
Braking torque 155 - 21 270 N.m
Disc Ø220 to 995
<ul style="list-style-type: none"> <li>• Electro-Hydraulic Thruster</li> <li>• Weight: 40 to 224 kg</li> </ul>



<b>T RANGE</b>
Braking torque 775 - 17 300 N.m
Disc Ø445 to 995
<ul style="list-style-type: none"> <li>• Braking by HYDROSPRING®</li> <li>• Weight: 160 kg</li> </ul>

## DRUM BRAKES



<b>SDB - FNS DRUM BRAKES</b>
Braking torque 60 - 11 000 N.m
Drum Ø150 to 750 mm
<ul style="list-style-type: none"> <li>• Standard DIN 15435</li> <li>• Weight: 28 to 441 kg</li> </ul>



<b>SAB DRUM BRAKES</b>
Braking torque 55 - 8800 lb.-ft.
Drum Ø6" to 30"
<ul style="list-style-type: none"> <li>• Standard AISE N.11</li> <li>• Weight: 70 to 980 lb</li> </ul>

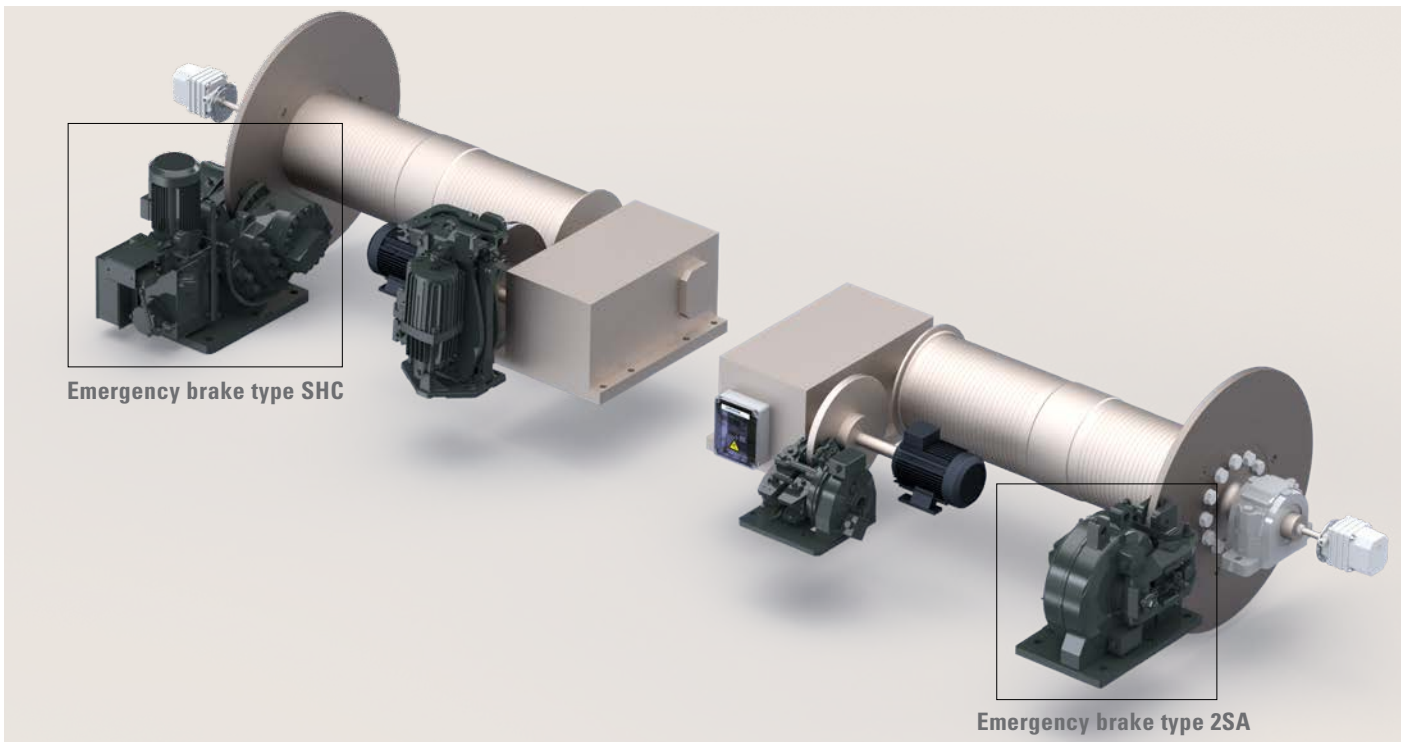


<b>FNS-T DRUM BRAKES</b>
Braking torque 60 - 4700 N.m
Drum Ø160 to 500 mm
<ul style="list-style-type: none"> <li>• Standard DIN 15435</li> <li>• Weight: 30 to 252 kg</li> </ul>

# EMERGENCY BRAKES

Emergency brakes are installed directly on the flange of the drums, and they are the last safety device in the event of a falling load. These brakes are applied in case of over-speed detection, power failure, mechanical transmission breakage or emergency stop controlled by operator. Many options are available: breather pot, special painting, protective cover, etc...

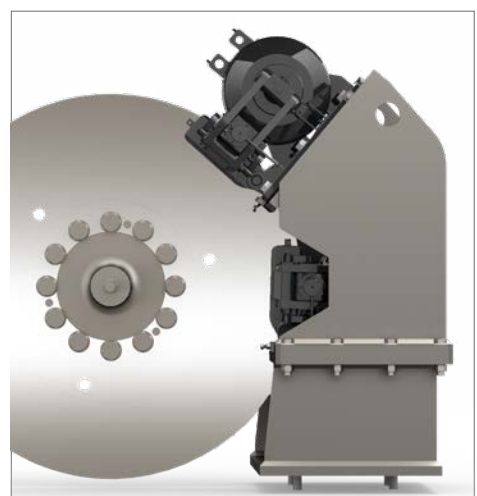
- **Electromagnetic brakes** type **SA** are references in the steel and nuclear applications. This range requires little maintenance.
- Stromag offers a large range of safety **hydraulic brakes**. Brakes type **SH** are designed to operate in the most severe environmental conditions of steel industry. Brakes type **SHD** can be mounted in restricted space.



**SHC RANGE**  
Integrated Hydraulic Power Pack with hydraulic connections



**Adaptation example for hoisting crane**  
3 calipers **SH25** on a bracket with HPP, disc Ø1600 mm



**Adaptation ex. for travelling crane**  
2 calipers **2SA** on a bracket for restricted space - disc Ø1600 mm



## ELECTROMAGNETIC BRAKES



**2SA**

Braking force 100 kN

- The most powerful electromagnetic brake
- Lifting applications of Steel Industry



**OOSA**

Braking force 60 kN

- Low maintenance level
- Association with **4205** electrical power unit for lowering operations





**OSA**

Braking force 31 kN

- Options: Hydraulic release - Breather pot - Special Painting - Steel cover for air gap seal...

## HYDRAULIC BRAKES TYPE SH


Type	Weight	Braking force
 SH1	35 kg	2 to 11 kN
SH5	110 kg	7.3 to 70 kN
SH9A/SH13	140 kg	55 to 130 kN
SH15/SH18B	270 kg	73 to 180 kN
SH25	440 kg	134 to 250 kN
SH32	600 kg	333 kN




### SH RANGE

- Symmetrical design
- Spring application - Hydraulic release
- Opening monitoring switch
- Full lining wear detection
- **Options:** Progressive braking system - Offshore protection High temperatures, steel industry conditions
- **SHS:** caliper mounted on a bracket
- **SHC:** caliper and HPP mounted on the same bracket

## HYDRAULIC BRAKES TYPE SHD

Type	Weight	Braking force
 SHD1	24 kg	3 to 11 kN
SHD2	60 kg	10 to 23 kN
SHD5A	108 kg	15 to 56 kN
SHD9	148 kg	43 to 100 kN
SHD18	395 kg	120 to 180 kN



### SHD RANGE

- Compact and modular design
- Spring application - Hydraulic release
- Opening monitoring switch
- Full lining wear detection
- Marine protection and low temperature materials
- Short response time
- Association with discs of different thicknesses
- **Options:** Opening, wear and temperature indication

# ELECTRICAL POWER UNITS

**Stromag electrical power units ensure a fast opening and closing time of the fail safe electromagnetic brakes. They have an “economic” mode which decreases the electric consumption and the heating of the brakes to provide an efficient and long lasting solution. Protected against overload and over-current, this range of power units ensures safe, reliable and high performance of your braking system.**

The switch-mode power supply units, type **AC64**, **AC32** and **AS100**, offer high quality and braking performance. These electrical power units are available in Polycarbonate or Steel enclosure. **4200** unit is proposed in panel mounted version or in casing protected version. It can supply several calipers. **4205** unit allows a progressive release of electromagnetic calipers to perform lowering operations.

Advantages
<ul style="list-style-type: none"> <li>• Simplicity of adjustment and use</li> <li>• Weight and size reduced</li> <li>• Quick diagnosis of faults by means of LEDs indications</li> </ul>



**AC64-FB & AC32**  
For calipers 600, K, CA2



**AS100**  
For calipers OSA, OOSA



**4200 & 4205**  
For calipers 4CA2, 3CA2, OSA, OOSA, 2SA



# HYDRAULIC POWER PACKS

Use of emergency brakes implies a perfect control of opening and closing times. This is why we designed and developed special Hydraulic Power Packs adapted to these critical industrial constraints. Whatever the type or the number of brakes necessary for your installation, whatever the distance that separates the braking system from the power unit, Stromag is able to provide a fitted solution to meet your needs.

OPTIONS	
<ul style="list-style-type: none"> <li>• Manual lowering</li> <li>• Delayed closing</li> <li>• Controlled braking torque</li> <li>• Enhanced security return circuit</li> <li>• SIMAN Intelligent system</li> </ul>	<ul style="list-style-type: none"> <li>• Electrical unit</li> <li>• Soft braking</li> <li>• MOPS (Manual Overload Protection System)</li> <li>• Indicators (clogging indicator, oil temperature indicator, oil level)</li> </ul>



**SHPU1**  
 Tank 5 L  
 Motor 0.37 or 0.75 or 2.2 kW  
 Weight with oil: 24 to 40 kg



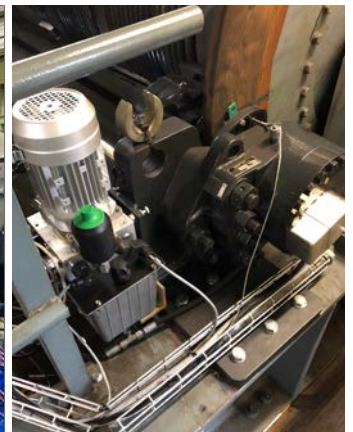
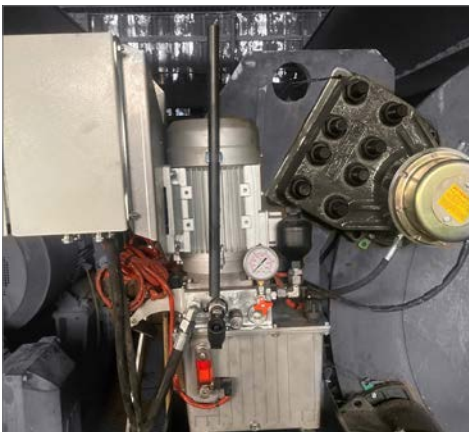
**SHPU2**  
 Tank 8 L / 11 L  
 Motor 0.75 or 2.2 kW  
 Weight with oil: 36 to 52 kg



**SHPU3**  
 Tank 35 L / 8 L  
 Motor 0.75 or 2.2 kW  
 Weight with oil: 46 to 110 kg



**SB210**  
 Tank 90 L  
 Motor 8.7kW  
 Weight without oil: 160 - 180kg

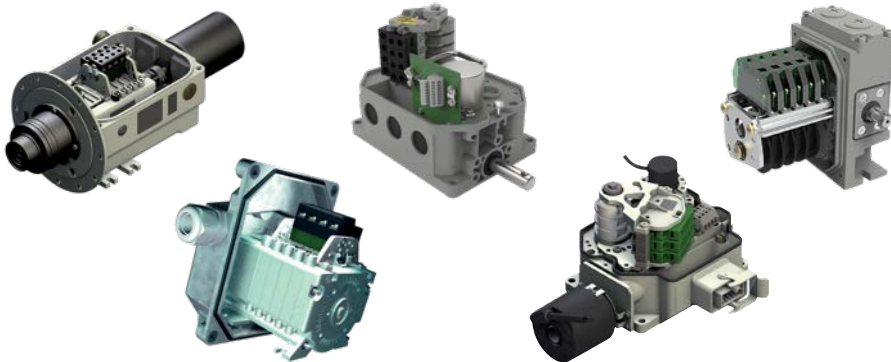




# LIMIT SWITCHES

Stromag has been building geared cam, lever limit switches and main power switches for over fifty years. With a wide range of gear systems, switching contacts, and housings of metal or polycarbonate, we can offer solutions for every application.

All analogue and digital encoder systems can be integrated. Our geared cam limit switches reliably switch off sequences of movements, and position or restrict these with independently and precisely adjustable cam discs. These geared cam limit switches can easily determine absolute positions to a high precision that can be converted into reliable additional data like e.g. sense of rotation and overspeed. Data can be transferred to **SIDEOS** monitoring systems.



## Geared Cam Limit Switches

- High repeatability due to precise gear design
- High reliability due to form fit design
- Gear ratios from 0.85 to 16000
- Plastic or metal housing
- IP ratings up to IP66
- Change-over and double-make/ double- break contacts available
- Positive opening contacts



## Lever/Counter-Weight Switches

- Heavy Duty Limit Switches
- Up to IP66
- Series 100 or HHEV
- Temperatures up to 120C° possible



## Cross Lever Switches

- 5 Positions (4 or 6 optional)
- Position shown on display window and by lever markings
- Silver or gold contacts
- Ratio  $i=1,25$
- IP 66



## Main Power Switches

- For direct switching of three phase-motors
- 42 and 62 usable revolutions
- Contacts for up to 200 Amps

# SIDEOS SPEED MONITORING MODULES

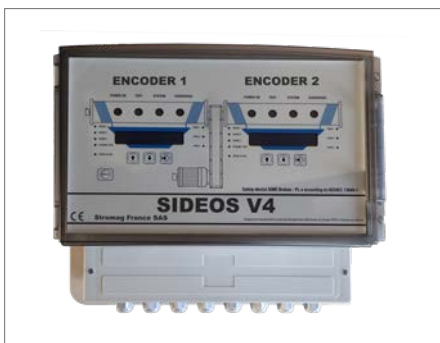
The modules SIDEOS are configurable and secure devices for speed monitoring, fitted with an efficient auto control system which secures the overall operation of the over-speed detection system.

They allow to obtain, when installation is correct a speed monitoring system secure up to category 4 with the performance level of PL = e according to the standard ISO/IEC 13849-1.



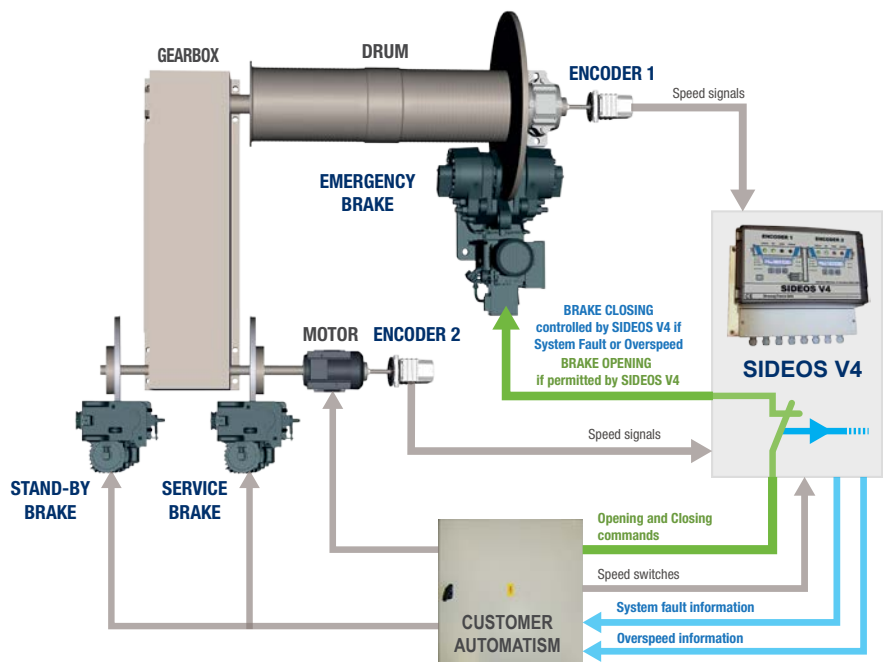
**SIDEOS One - SIDEOS SC**

- **SIDEOS One** monitors 3 speed thresholds, the stop and the rotation direction of the installation. It detects Overspeed, Satic and Dynamic Slipping
- **SIDEOS Sc** monitors the speed according to a variable speed threshold (for ex. in case of joystick control)



**SIDEOS V4**

**SIDEOS V4** is a configurable Monitoring System is designed to secure the kinematic chain of lifting equipment. It can be used in Drum/Motor or Drum/Drum configurations, see in the opposite diagram a Drum/Motor configuration.



**SIDEOS V4 is set according to the lifting characteristics:**

- Characteristics on Encoder N°1 side
- Characteristics on Encoder N°2 side

**It receives:**

- The speed signals from the 2 incremental encoders
- The functional orders of the lifting control of the handling equipment

**It detects all the faults of lifting speed:**

- Overspeed PV and GV
- Kinematic Chain Break
- Static Slipping
- Dynamic Slipping

**In case of fault :**

- It drives the opening of the braking control circuit downstream the command circuits.
- It transmits the information to the command and signals to the operator the triggering origin via alphanumeric displays

**It records the last 3 messages**

SioT concept includes several modules, each having specific functions:

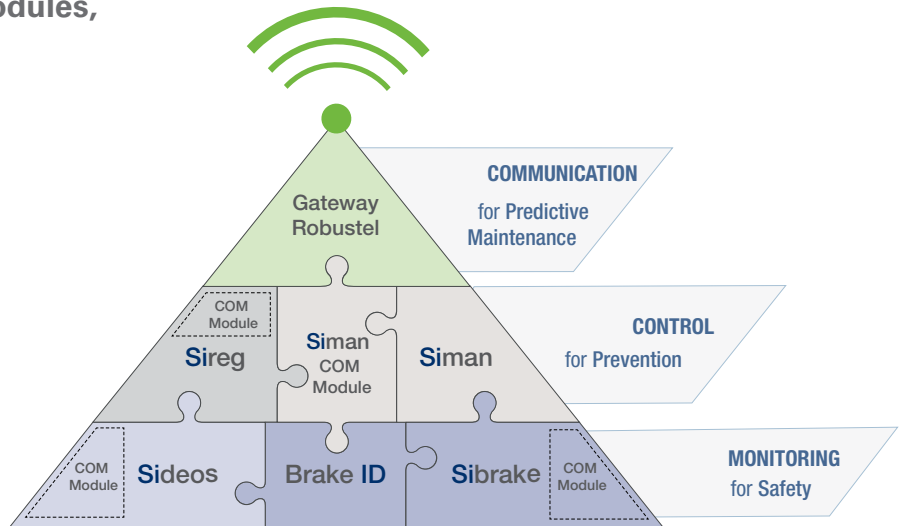
**Siman** : HPP Control and Monitoring

**Sibrake** : Brake monitoring

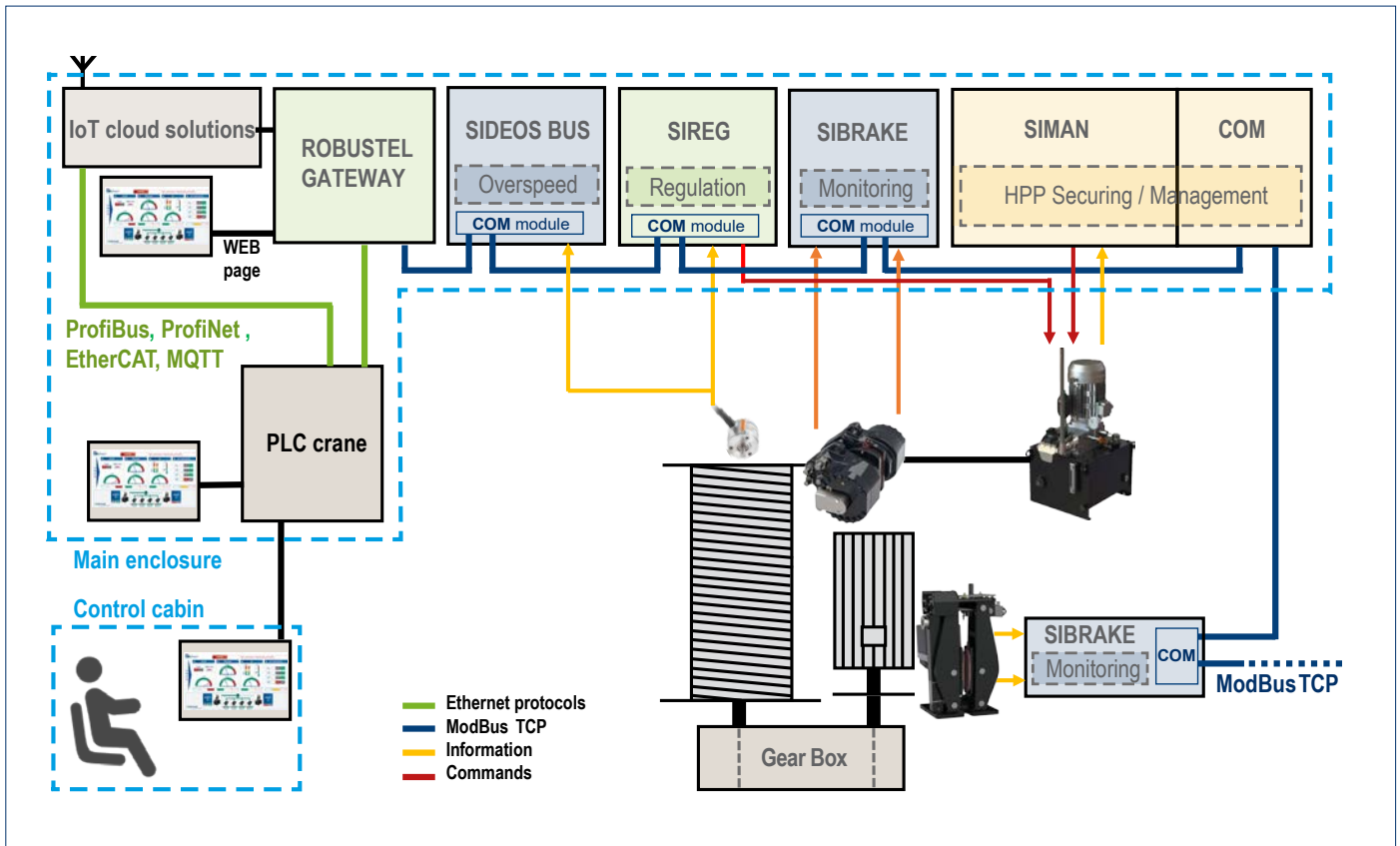
**Sideos** : Speed Monitoring

**Sireg** : Regulated Braking

These modules can exchange various information with each other. They can be selected alone or combined accordingly to the installation requirements.



## SioT concept







## HYDRAULIC POWER PACKS MONITORING

**SIMAN is an intelligent system for monitoring and management of the good operation of Hydraulic Power Packs whatever their functionalities.**

This system is a reliable solution for safety with:

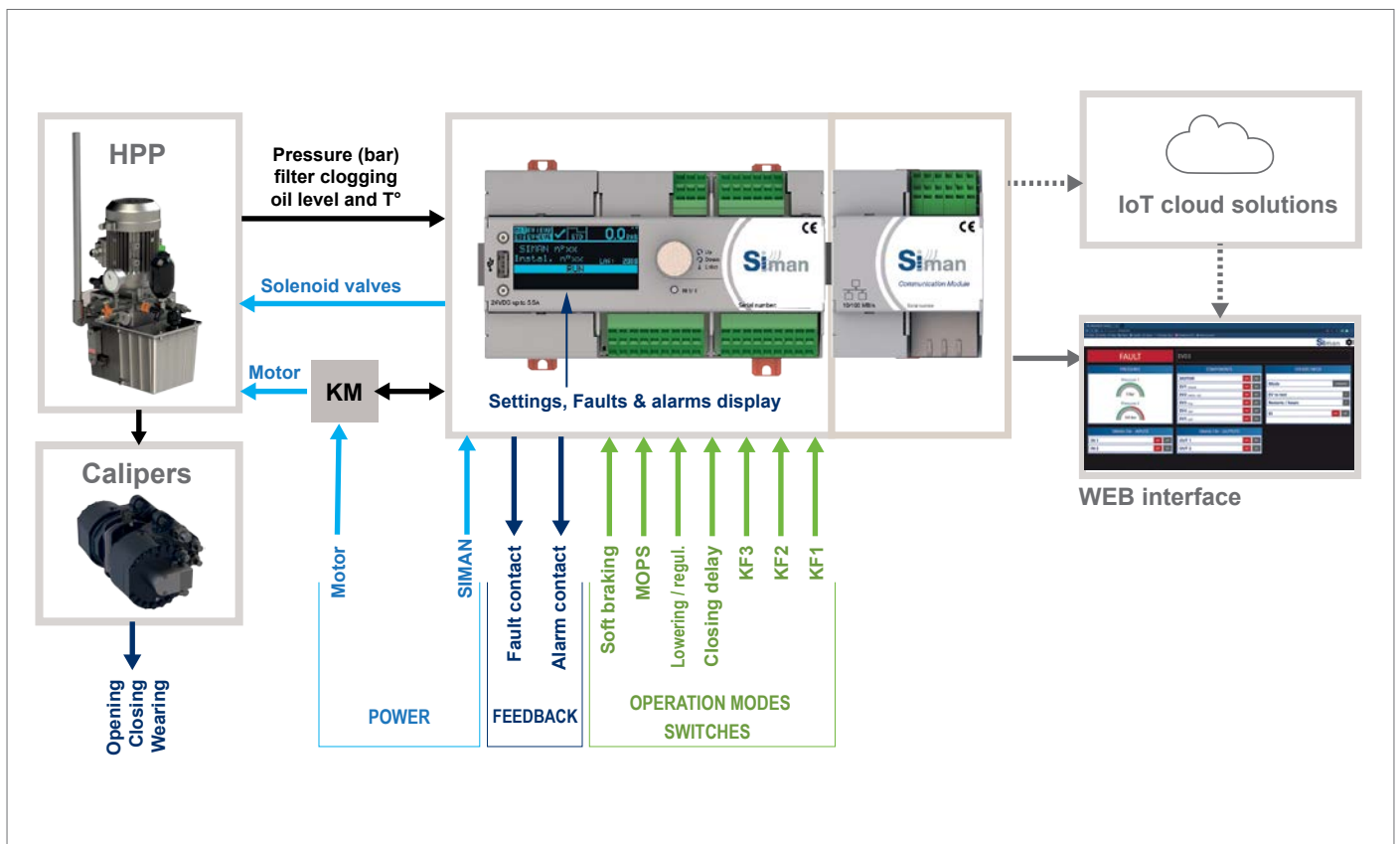
- according to standard NF EN ISO 13849, a performance level PLd, category 2 system, MTBF = high, DC = high
- a service life of 1 million of ON/OFF cycles

It drives the HPP motor pump and the solenoid-valves. To ensure safety, it controls the good operation of the solenoid-valves and the oil return to the tank. For optimal operation, it monitors the HPP parameters.

**SIMAN CM** communication module allows connection to a Ethernet network (ModBus TCP server - WEB interface).



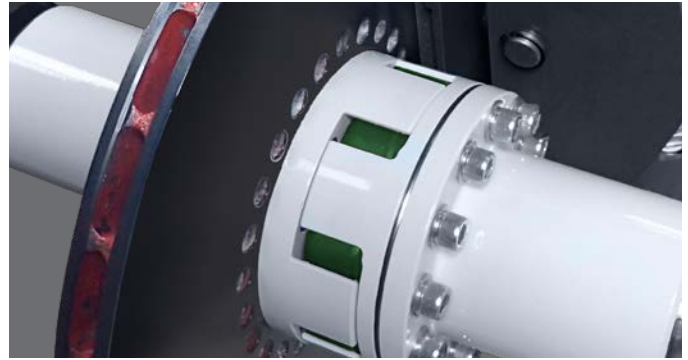
### Diagram of the SIMAN inputs and outputs



# BRAKE DISCS AND COUPLINGS

As a complement to its disc brakes, Stromag proposes three types of disc couplings to offer a complete braking system solution.

Stromag provides solid and ventilated discs with an external diameter from 175 to 995 mm, and a thickness of 15 mm (mono-bloc disc), 30 mm (solid and ventilated) or 42 mm (ventilated disc).



## Stromag PERIFLEX® RANGE

Highly-Flexible couplings

- Rubber-fabric tyre, mounted and removed without moving the machines
- compensate extreme offsets, absorb torque peaks and damp vibrations



## SDF RANGE

Double Engagement Gear Couplings

- 2 flanged sleeves with internal spur gear teeth, linked with steel bolts
- 2 crown toothed hubs allowing the best possible alignment



## SDKL - SVKL RANGE

Highly-Flexible couplings

- Cam rings and flexible element, mounted and removed without moving the machines
- Damping of shocks & torsional vibrations

# DRUM COUPLINGS



## SVT RANGE

- Drums diameters: Ø200 to 630 mm
- Flexible couplings with cam rings and flexible element
- Simple mounting/dismounting
- Shocks and torsional vibrations damping



## PB-C RANGE

- Drums diameters: Ø200 to 710 mm
- Made of two cast iron hubs mounted with pins fitted with rubber bushes
- Reduction of shock loads and resonance effect of critical velocities

# BARREL COUPLINGS



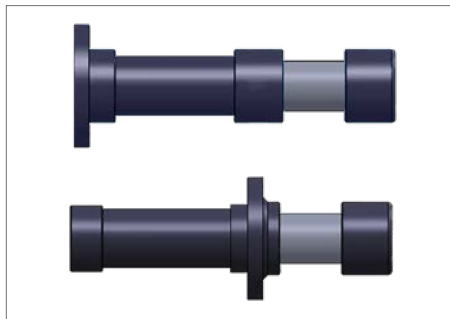
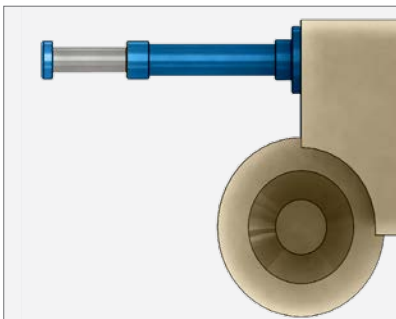
## SBC RANGE

- Flange diameter: Ø250 to 850 mm
- Shaft housing: Ø66 to 425 mm
- Steel coupling for connection of the slow rotating shaft of a gearbox to the rope drum of hoisting equipment.

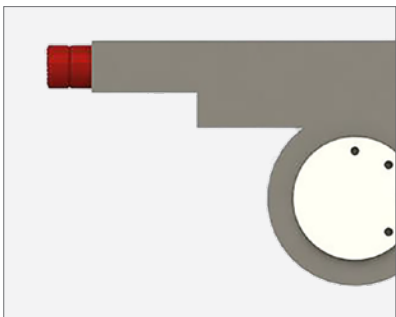
# HYDRAULIC & POLYURETHANE BUFFERS

Buffers used to damp the energy resulting from the crash in rail transport systems and crane systems working with various load capacities and in different velocities are very important for extended life of the transport system and for security.

Stromag provides 2 types of buffers : polyurethane and hydraulic with many variations according to energy buffering capacities, strokes and connection types. In the selection of buffers, it is important to prefer the buffers with optimum values.



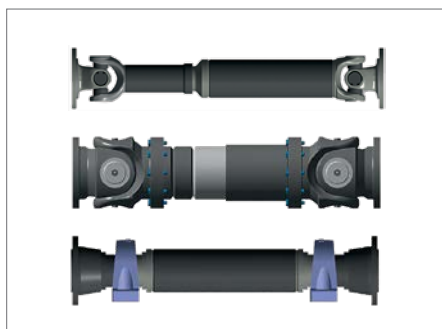
Hydraulic Buffers PHS
Damping force 70 - 670 kN
<ul style="list-style-type: none"> <li>• 2 types: rear or front mounting</li> <li>• 4 sizes: 063, 080, 100 and 125</li> <li>• 15 strokes (that makes 120 different models)</li> <li>• Strokes: 100 to 800 mm</li> <li>• Total length max.: 456 to 2114 mm</li> <li>• Options: Safety chain - Protection cover</li> </ul>



Polyurethane Buffers PPS
Damping force 6 - 40 kN
<ul style="list-style-type: none"> <li>• Rear mounting with bolts</li> <li>• 4 sizes: 80, 125, 160 and 200 mm</li> <li>• Capacity: 1500 to 25000 J</li> <li>• Total length max.: 80 to 200 mm</li> </ul>

# CARDAN SHAFTS

Transmission of an angular rotation  
Coupling of two rotating non-aligned shafts



Cardan shafts ACS
Torque 600 - 3 900 000 Nm
<ul style="list-style-type: none"> <li>• 7 types: with or without length compensation, with or without flanges</li> <li>• 24 sizes</li> <li>• Useful diameter: 76 to 840 mm</li> <li>• Length max.: 190 to 4500 mm</li> </ul>



# STORM BRAKES

Stromag provides a large range of storm brakes to secure outdoor cranes such as ship to shore cranes, automated stacking cranes and rail-mounted gantry cranes.

Storm brakes are parking and safety devices which prevent a crane from uncontrolled movement along the rail in case of sudden bursts of wind.

## RAIL CLAMPS



### Limited Rail Clamps LRBS

Braking Force: up to 650 kN

- Braking by spring / Hydraulic release
- Guided with hardened steel guiding blocks
- Float: Horizontal  $\pm 30\text{mm}$   
Vertical  $\pm 5\text{mm}$



### Guided Rail Clamps GRBS

Braking Force: up to 1000 kN

- Braking by spring / Hydraulic release
- Guided with cylindrical low friction rollers
- Float: Horizontal  $\pm 30\text{mm}$   
Vertical  $\pm 25\text{mm}$



### Retractable Rail Clamps RRBS

Braking Force: up to 1200 kN

- Braking by spring / Hydraulic release
- Brake pads and complete mechanism is retractable
- Float: Horizontal  $\pm 30\text{mm}$   
Vertical  $\pm 25\text{mm}$

## RAIL BRAKES



### Rail Elephant Foot RPS

Braking force up to 300 kN

- Braking by spring on the top of the rail
- Hydraulic release
- Balanced braking force
- Oversized longer lasting springs for reduced maintenance

## WHEEL BRAKES



### Wheel Electric Brakes WBES

Braking force up to 120 kN

- Spring set
- Fully electric release
- No hydraulic components
- Setting time adjustable from 3 to 30s
- Shoe alignment device



### Wheel Hydraulic Brakes WBHS

Braking Force: up to 120 kN

- Spring set
- Hydraulic release
- Setting time adjustable from 3 to 30s
- Shoe alignment device
- Mechanical brake release

LRBS



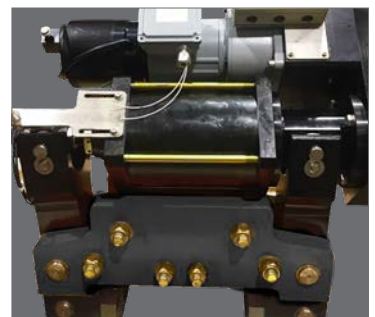
RRBS



RPS



WBES



# MOTOR BRAKES

With their high degree of protection, the Stromag Motor brakes fulfill the highest requirements for durability, robustness and seawater environment.

Spring-applied **4BZFM** brake is flood- and seawater-proof for offshore and marine applications.

**NFF** brake is designed for compact industrial and crane applications with a high protection against harsh environment.

**HPB** Brake is a modular braking system as 2 face and 4 face design for highest performance in smallest space.



4BZFM Brake
Braking Torque: 63 to 11000 Nm
<ul style="list-style-type: none"> <li>• Spring applied</li> <li>• Electromagnetic release</li> <li>• Protection up to IP67</li> <li>• Designed for marine applications</li> <li>• Options: Tachometer mounting, terminal box, anti-condensation heater, micro-switches</li> </ul>

NFF Brake
Braking Torque: 20 to 40000 Nm
<ul style="list-style-type: none"> <li>• Spring applied</li> <li>• Electromagnetic release</li> <li>• Protection up to IP66</li> <li>• For compact industrial applications</li> <li>• Options: Tachometer mounting, terminal box, anti-condensation heater, micro-switches</li> </ul>

HPB Brake
Braking Torque: 80 to 5000 Nm
<ul style="list-style-type: none"> <li>• Spring applied</li> <li>• Electromagnetic release</li> <li>• Protection up to IP67</li> <li>• Designed for high speed applications</li> <li>• Options: Tachometer mounting, terminal box, anti-condensation heater, micro-switches</li> </ul>

# WARNER ELECTRIC BRAKE

The **ERX** Brake range is a pre-assembled spring-applied Electromagnetic brake used for parking and emergency braking.

The **ERX** Brake can be adapted to different application needs in speed, energy or torque, thanks to 3 different friction materials.

The **ERX** Brake can be selected with multiple options such as hand-lever release, enclosure protection, detection & redundancy or a combination of those.

Standard detection option, previously mechanical contact technology, is now contactless thanks to the new Warner Electric Sensor “**WES**”.



ERX Warner brakes
Braking Torque: 5 to 75 Nm
<ul style="list-style-type: none"> <li>• Spring operated / electrically released</li> <li>• Compact design</li> <li>• Single or Double brake version</li> <li>• Very easy installation</li> <li>• Single voltage as standard</li> <li>• Duty cycle: 100% energized</li> <li>• Indoor application</li> <li>• Non-stick friction material</li> <li>• Hand lever for manual releasing</li> </ul>

# OUR KNOW-HOW AT YOUR DISPOSAL

Reactivity, availability and listening of the customer are values which define our teams. We put all our experience and knowledge at your disposal:



## RESEARCH & DEVELOPMENT - TESTS

Stromag invests into increasingly sophisticated resources. Unique test facilities like our braking simulation tower and our dynamic test benches enable to:

- test all the brakes in real conditions of operation, in environments that can be extreme (low and high temperatures),
- carry out pads wearing tests as part of our research into friction materials.



## TRAINING

Our after-sale service team provides customers training sessions: upgrade operations on-site or trainings in our production center in France.

Our courses are designed for a wide audience: from the designer to the user with real-use conditions. Recognized as a training organization, the Stromag training team is at your disposal to examine all your specific needs.



## RENOVATION

A real renovation is carried out on the brakes to be repaired: After a complete disassembly of the brake, all the constituent parts are checked. The brake is upgraded according to the last technical developments. So the customer receives brakes having the same performances as the new brakes with a new warranty period of 12 months.

### Advantages

- |                                                                                                                                                                                                            |                                                                                                                                                                |
|------------------------------------------------------------------------------------------------------------------------------------------------------------------------------------------------------------|----------------------------------------------------------------------------------------------------------------------------------------------------------------|
| <ul style="list-style-type: none"><li>• A team of experts at your disposal</li><li>• Reactivity of the interventions</li><li>• Study of the specific requirements</li><li>• Secured installation</li></ul> | <ul style="list-style-type: none"><li>• Optimal operation of the braking systems</li><li>• Preventive maintenance</li><li>• Expertise sustainability</li></ul> |
|------------------------------------------------------------------------------------------------------------------------------------------------------------------------------------------------------------|----------------------------------------------------------------------------------------------------------------------------------------------------------------|





## DIAGNOSIS

For installations including an important fleet of brakes, the diagnosis on-site allows to obtain an accurate picture of the state of the installation and to know the urgency order of the different maintenance operations to be carried out.

To achieve a maximal reliability in compliance with the safety regulations, our teams help the customer to realise a self-diagnosis of its braking systems.



## INTERVENTION

Stromag After Sales Service Department operates quickly and efficiently on all installations worldwide for:

- the commissioning of the braking systems,
- all troubleshooting operations.

Our team consists of experts and technicians who work on all applications (steel industry, port cranes, nuclear cranes, cable-way, conveyors...)



## REVAMPING

Rehabilitation, modernization, revamping of your braking system, increase the safety, reliability and economic performance of your crane without modification of the installation design.

Thanks to its expertise in industrial engineering and maintenance, our team can manage the revamping of all types of equipment on your site by installing:

- Braking systems offering new performances,
- Monitoring and control systems for prevention and predictive maintenance (as a SiOT system adapted to your requirements).

For any information or intervention needs, please contact us.



[sales.LaGureche@regalrexnord.com](mailto:sales.LaGureche@regalrexnord.com)

# TAILOR-MADE SOLUTIONS

**Stromag offers tailor-made solutions for the more specific requests of the customers. From design to conception of the product, our research and development team focuses all efforts to find the best technical solution to suit the customers requirements.**

## CUSTOMIZED SOLUTIONS FOR HEAVY DUTY INDUSTRY

Since 1966, Stromag has been supplying braking solutions adapted to the requirements of the iron and steel industry all over the world.

Our tailor-made solutions enable:

- several braking modes: on/off braking, regulated braking, load lowering, with Human Machine Interface
- an easy maintenance: holding tools and hydraulic release tools adapted to all the calipers of the installation.



Photo courtesy of TAIM WESER



## OUTSTANDING SHIP LIFTS

Stromag was chosen to supply accurate braking systems for the ship lifts of the hydroelectric stations of Silin, Shatuo and Goupitan on the busy Wujang River in China.

For each project, a huge braking system secures the lifting of the boat-reservoir (weight up to 3300 tons), to a maximum height of 79 meters. It is composed of hydraulic brakes types SH32 and SHD5, and specific Hydraulic Power Packs with electrical command and monitoring.

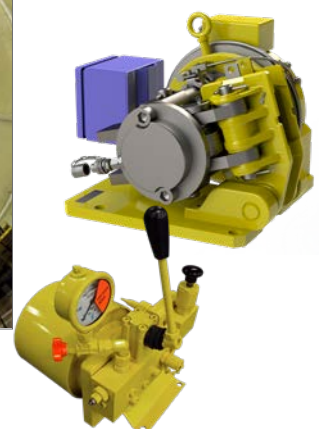
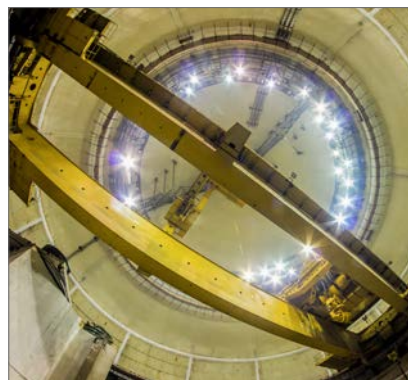


## NUCLEAR APPLICATIONS

Stromag provides worldwide braking solutions meeting all safety and quality requirements of Nuclear Industry.

Our braking systems have been selected and certified to equip the polar cranes reactor buildings, as well as cranes of turbine, pumphouse, fuel and auxiliary buildings of Hinlkey-Point EPR.

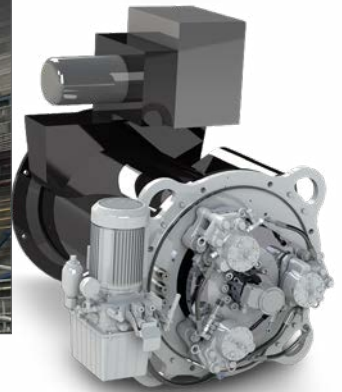
These braking systems include electromagnetic brakes with or without hydraulic release device, power supplies, specific lowering devices, hydraulic emergency brakes and discs couplings.



## HEAVY LIFT OFFSHORE CRANES

Modular Stromag SHD1 braking systems have been selected by several leading global OEM to equip large mass cranes installed on offshore construction vessels which provide heavy lifting capability to support surface or sub-sea asset installations (as for ex.: wind turbines, pipelines).

These braking systems offer an economical braking solution: they are factory-tested and designed to be mounted directly on the rear of the motors (400 kW and up).



## PORT CRANE 10B in TOULON

SIME Brakes braking systems ensure the safety of the port crane 10B of the naval base of Toulon. This boom crane has a lifting capacity of 120 tons at 47 meters.

The braking systems, tested on seismic bench, include electromagnetic calipers 3CA2, electrical power units AC32-50, hydraulic calipers SH5 and SH25 and hydraulic power packs CE8L and CE12L especially designed for delayed or full braking, and manual lowering of the load with over-speed safety.



## PIONEERING SPIRIT VESSEL

MCH120 type brakes have been specifically developed and manufactured by Stromag to equip the Pioneering Spirit vessel. This huge vessel is the world's largest construction vessel, designed to install and remove offshore oil and gas platforms.

More than 550 MCH120 type brakes ensure a firm holding of the topsides horizontal lifting beams in their transverse motion along the vessel deck under the most adverse weather conditions.





## Stromag Facilities

### Europe

#### Germany

Hansastraße 120  
59425 Unna - Germany  
+49 (0) 23 03 102 0  
Clutches & Brake Couplings,  
Geared Cam Limit Switches, Discs

#### France

Avenue de l'Europe  
18150 La Guerche sur L'Aubois - France  
+33 (0)2 48 80 72 72  
Disc Brakes & Drum Brakes

#### Great Britain

Amphill Road  
Bedford, MK42 9RD - UK  
+44 (0)1234 324347  
Electromagnetic Clutches & Brakes,  
Industrial Caliper Brakes

### North America

#### USA

31 Industrial Park Road  
New Hartford, CT 06057 - USA  
860-238-4783  
Electromagnetic Clutches & Brakes

300 Indiana Highway 212  
Michigan City, IN 46360 - USA  
219-874-5248

#### Couplings

2800 Fisher Rd.  
Wichita Falls, TX 76302 - USA  
940-723-3400  
Geared Cam Limit Switches,  
Industrial Caliper & Drum Brakes

### South America

#### Brasil

Avenida João Paulo Ablas, 2970  
Jardim da Glória, Cotia - SP,  
06711-250 - Brasil  
+55 (11) 4615-6300  
Flexible Couplings, Bearing  
Isolators, and Coupling Guards

### Asia Pacific

#### China

T40B -5, No. 1765 Chuan Qiao Road  
Pudong 201206, Shanghai - China  
Tel +86 21-60580600

Clutches & Brake Electromagnetic  
Clutches & Brake Coupling Industrial  
Caliper & Drum Brakes, Disc Geared  
Cam Limit Switches

#### India

Gat No.: 448/14, Shinde Vasti, Nighoje  
Tal Khed, Pune- 410 501  
+91 2135 622100

Clutches & Brake Electromagnetic  
Clutches & Brake Coupling Industrial  
Caliper & Drum Brakes, Disc Geared  
Cam Limit Switches Wind Brakes

### Renewable Energy

#### Denmark

Jernbanevej 9  
5882 Vejstrup  
+45 63 255 255  
Wind Brakes



Scan to see all  
the brands of  
Regal Rexnord

Neither the accuracy nor completeness of the information contained in this publication is guaranteed by the company and may be subject to change in its sole discretion. The cost and performance characteristics of these products may vary depending on the application, installation, operating conditions and environmental factors. The company's terms and conditions of sale can be viewed at <http://www.stromag.com/terms-and-conditions/sales-terms-and-conditions>. These terms and conditions apply to any person who may buy, use or a product referred to herein, including any person who buys from a licensed distributor of these branded products.

©2023 by Stromag LLC. All rights reserved. All trademarks in this publication are the sole and exclusive property of Stromag LLC or one of its affiliated companies.

**BIBUS**<sup>®</sup>  
SUPPORTING YOUR SUCCESS

BIBUS SK, s.r.o  
Trnavská 31, SK-94 901 Nitra

Tel.: 037/ 7777 911    Email: [sale@bibus.sk](mailto:sale@bibus.sk)  
Fax.: 037/ 7777 999    <http://www.bibus.sk>