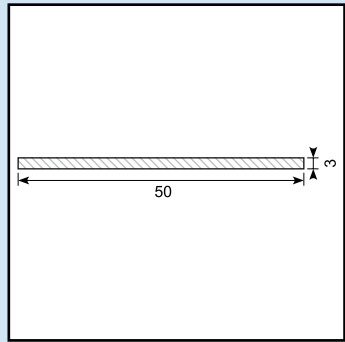
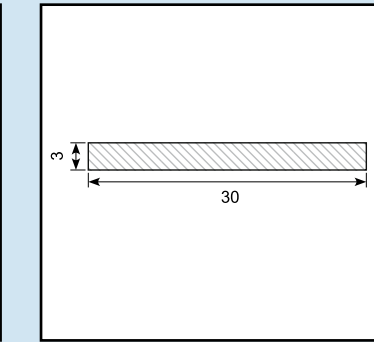
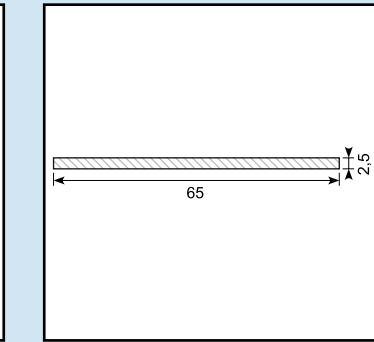
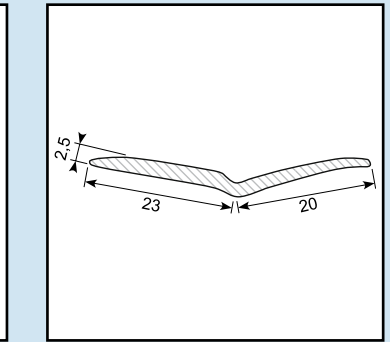
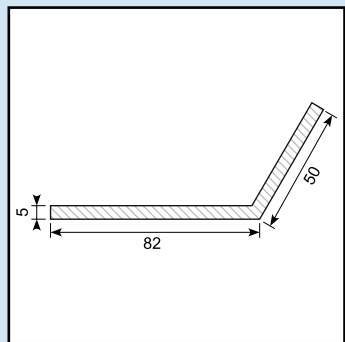
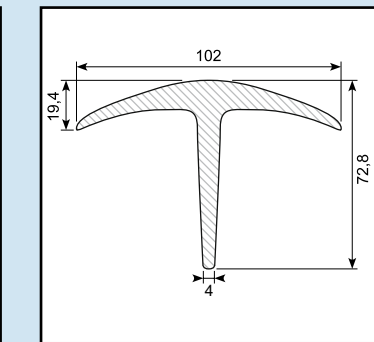
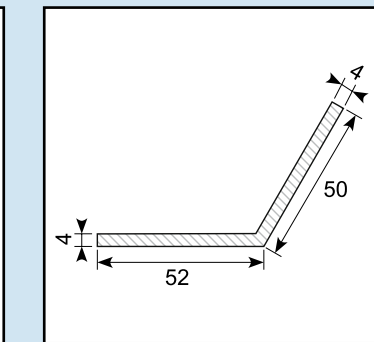
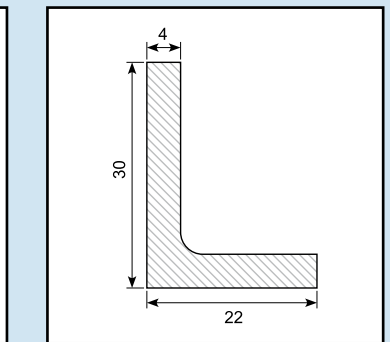
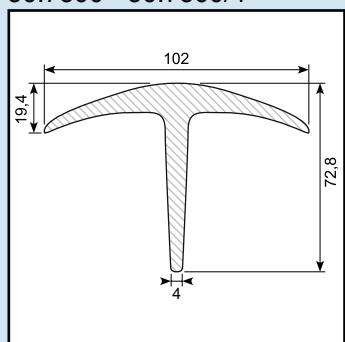
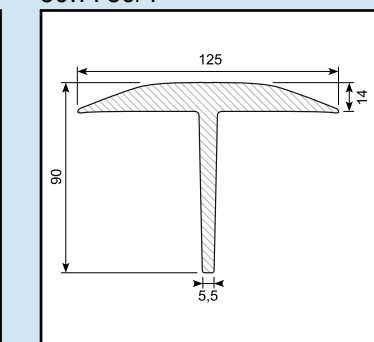
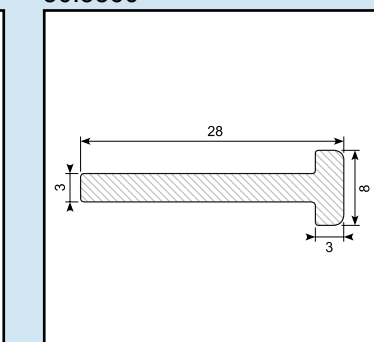
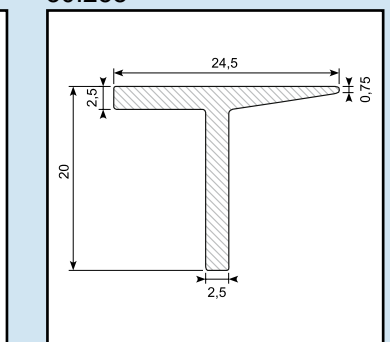
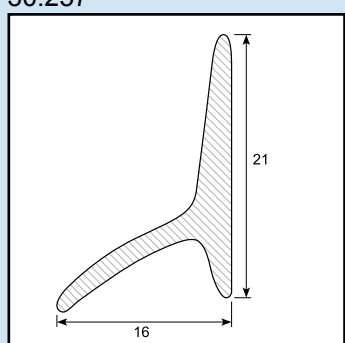
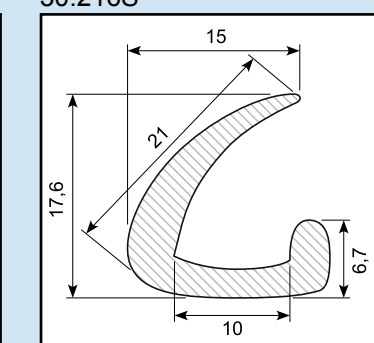
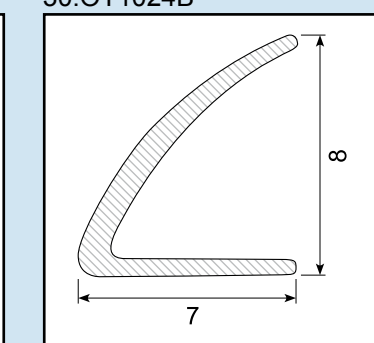
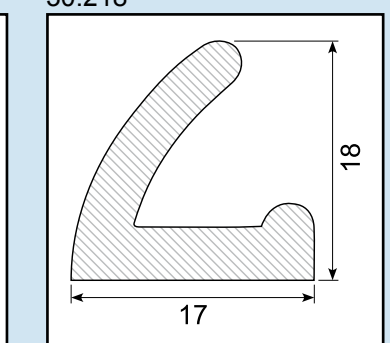

Special profiles / Specialprofiler

<p>30.602</p> 	<p>30.600</p> 	<p>30.601</p> 	<p>30.262</p> 
<p>Material: EPDM black Hardness: SH 65</p>	<p>Material: EPDM black Hardness: SH 65</p>	<p>Material: EPDM black Hardness: SH 65</p>	<p>Material: EPDM black Hardness: SH 65</p>

<p>30.7696</p> 	<p>30.7300/4Y</p> 	<p>30.7367</p> 	<p>30.220L</p> 
<p>Material: CR black Hardness: SH 65</p>	<p>Material: EPDM yellow Hardness: SH 65</p>	<p>Material: CR black Hardness: SH 65</p>	<p>Material: CR black Hardness: SH 65 Length: 6,5 m</p>

<p>30.7300 - 30.7300/4</p> 	<p>30.7780/4</p> 	<p>30.5560</p> 	<p>30.258</p> 
<p>Material: EPDM black Hardness: SH 65 Length 30.7300: 3 m Length 30.7300/4: 4 m</p>	<p>Material: EPDM black Hardness: SH 65 Length: 4 m</p>	<p>Material: EPDM black Hardness: SH 65</p>	<p>Material: EPDM black Hardness: SH 65</p>

<p>30.257</p> 	<p>30.216S</p> 	<p>30.OT1024B</p> 	<p>30.218</p> 
<p>Material: EPDM black Hardness: SH 65</p>	<p>Material: EPDM black Hardness: SH 65</p>	<p>Material: Silicone black Hardness: SH 60</p>	<p>Material: EPDM black Hardness: SH 65</p>

30.OT1024 - 30.OT1024U

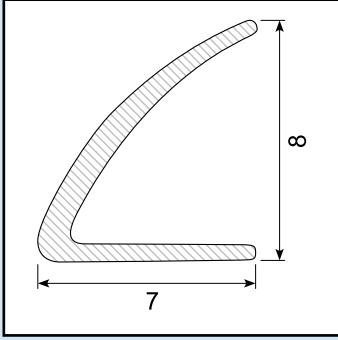

Material: Silicone white
Hardness: SH 60
30.OT1024 with adhesive

31.072

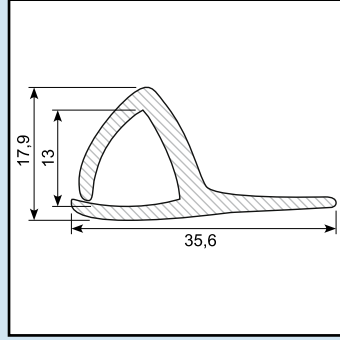

Material: EPDM black
Hardness: SH 65

30.7795

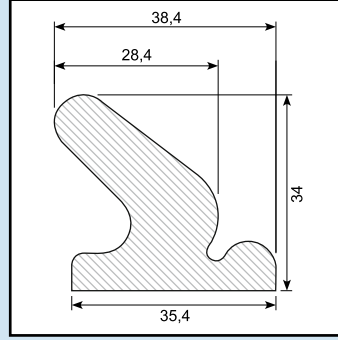

Material: EPDM black
Hardness: SH 65

30.7411

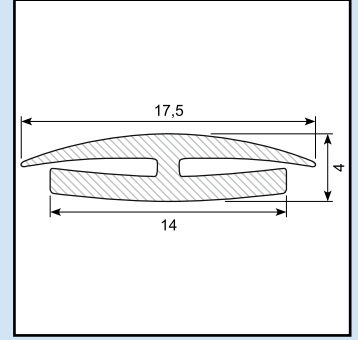

Material: EPDM black
Hardness: SH 84

30.762

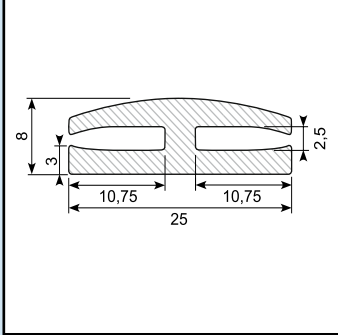

Material: EPDM black
Hardness: SH 65

30.7266

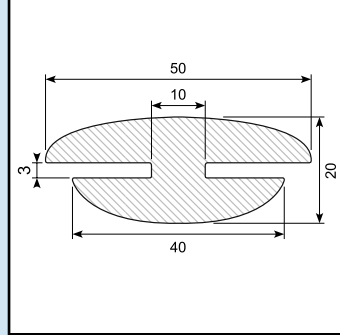

Material: EPDM black
Hardness: SH 65

30.7770

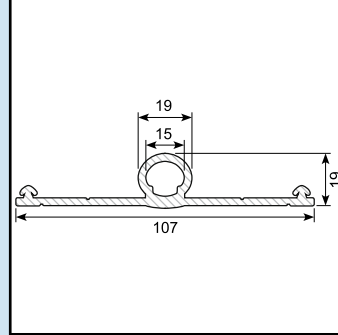

Material: EPDM black
Hardness: SH 65

30.7648

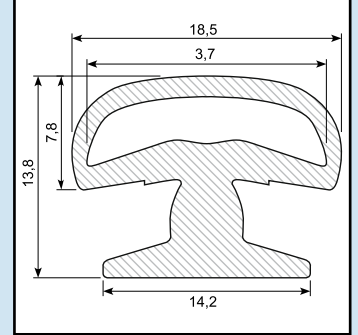

Material: EPDM black
Hardness: SH 65

30.5881

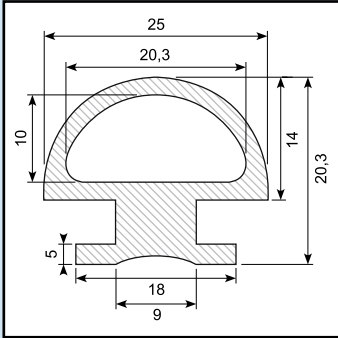

Material: EPDM black
Hardness: SH 65

30.OT1387

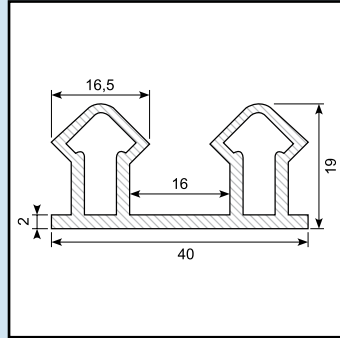

Material: Silicone grey
Hardness: SH 60

30.OT3272

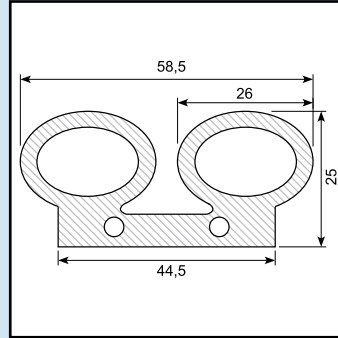

Material: Silicone blue
Hardness: SH 60

30.7645

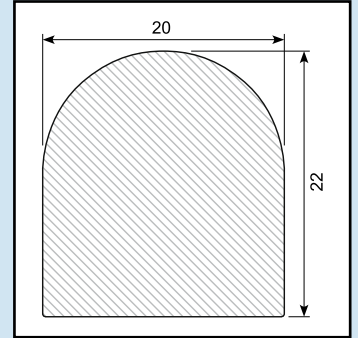

Material: EPDM black
Hardness: SH 45

30.50967

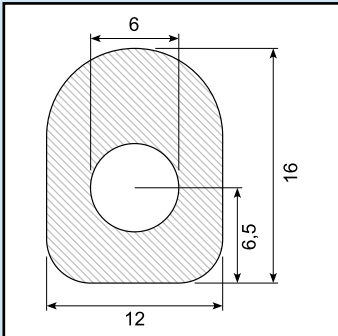

Material: NBR black
Hardness: SH 65

30.7559

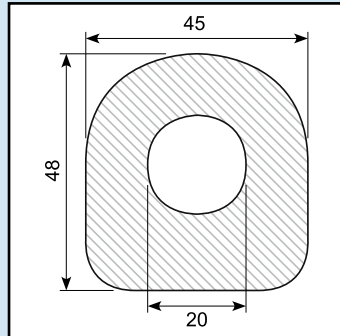

Material: NBR black
Hardness: SH 60

30.29300-129

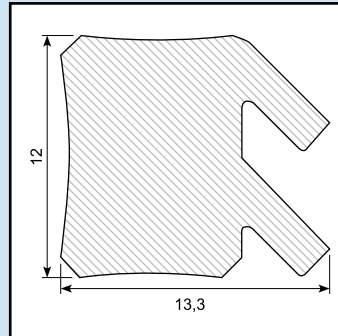

Material: CR black
Hardness: SH 65

30.29300-130

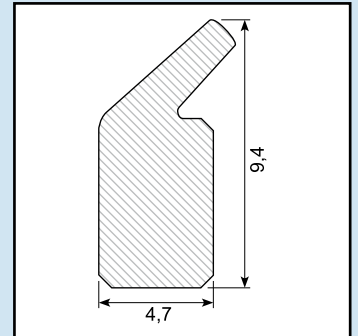

Material: CR black
Hardness: SH 65

30.7811

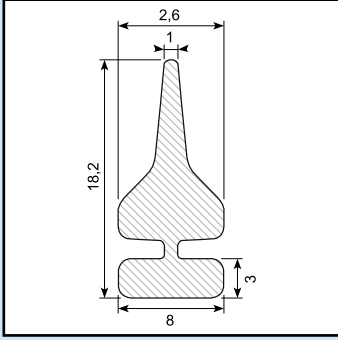

Material: EPDM black
Hardness: SH 60

31.702

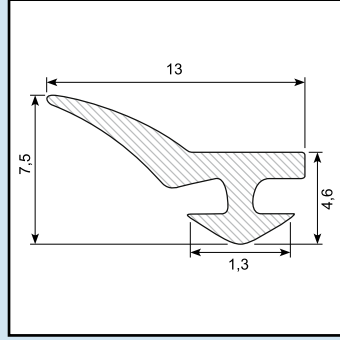

Material: EPDM black
Hardness: SH 70

30.6759

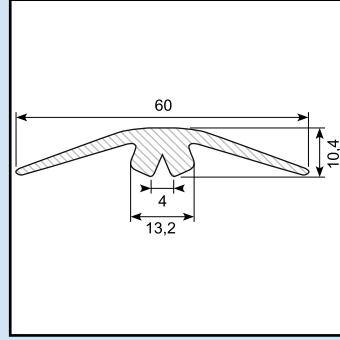

Material: EPDM black
Hardness: SH 65

30.6944

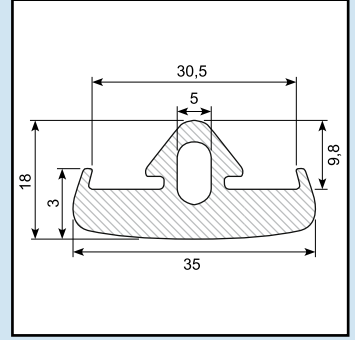

Material: EPDM black
Hardness: SH 65

30.5550M

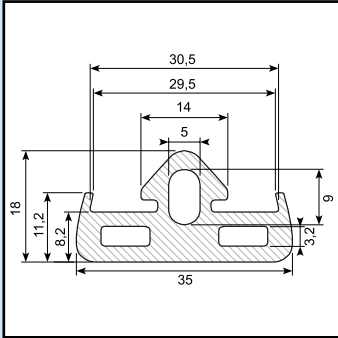

Material: EPDM black
Hardness: SH 65

30.OT3354

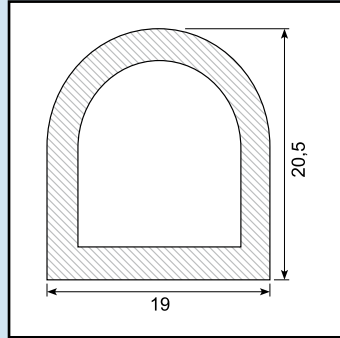

Material: Silicone white

30.7519

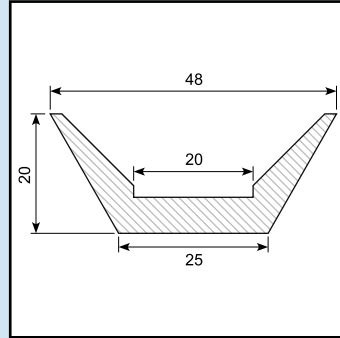

Material: EPDM black
Hardness: SH 65
Length: 2 m

30.7519NBR

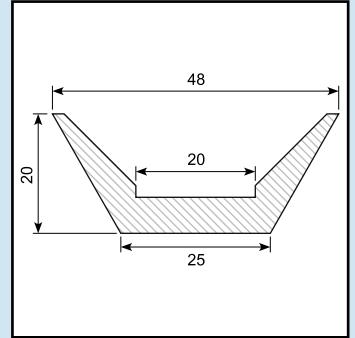

Material: EPDM grey
Hardness: SH 65
Length: 2 m

30.7845

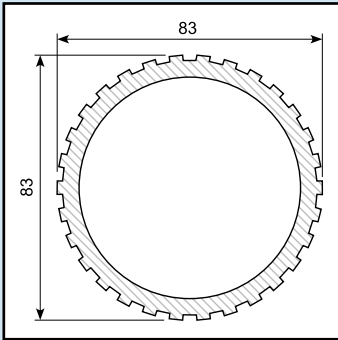

Material: SBR black
Hardness: SH 70

30.7106

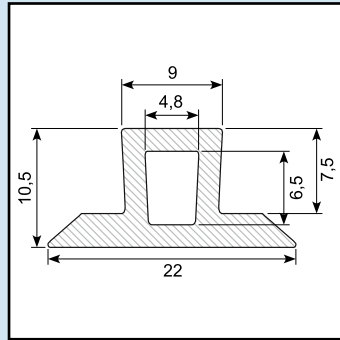

Material: EPDM black
Hardness: SH 65

30.5596

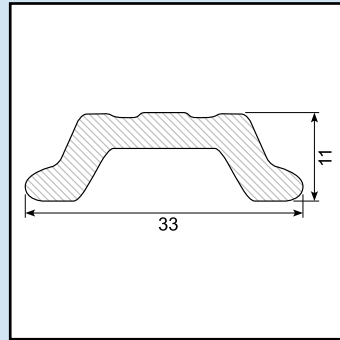

Material: EPDM black
Hardness: SH 65

31.087

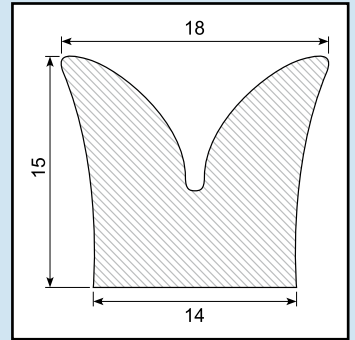

Material: EPDM black
Hardness: SH 65

30.7249

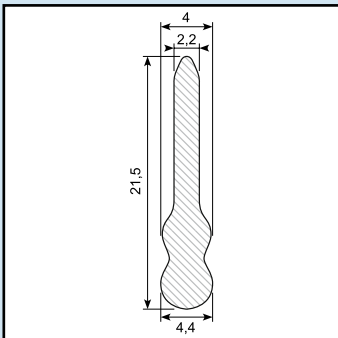

Material: CR black
Hardness: SH 70

30.OT1092

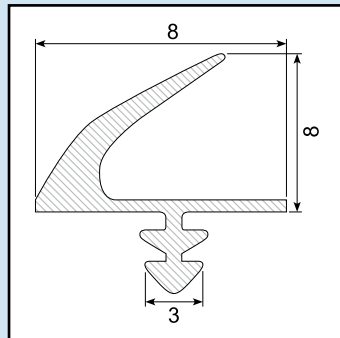

Material: Silicone white

30.5981

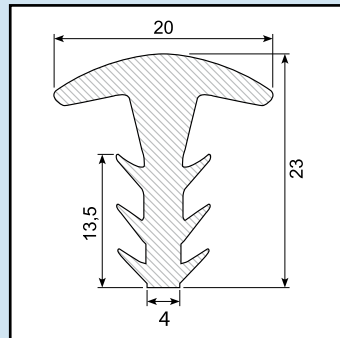

Material: EPDM black
Hardness: SH 65

30.2653

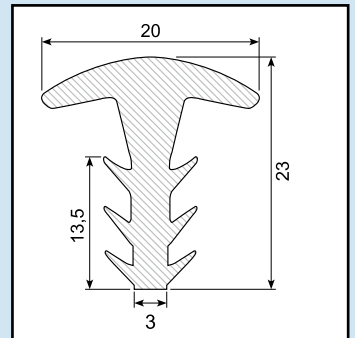

Material: EPDM black
Hardness: SH 65

30.8199

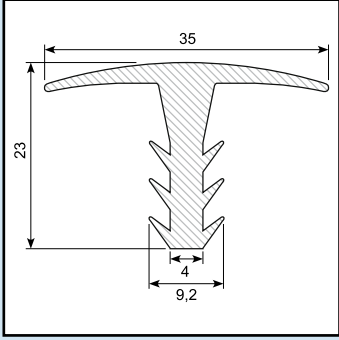

Material: EPDM black
 Hardness: SH 65
 Length: 4 m

30.190

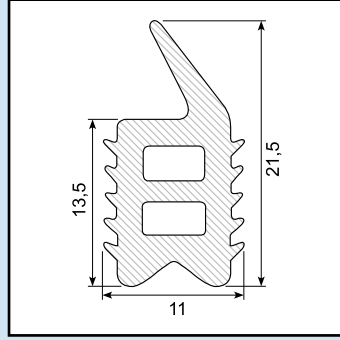

Material: TPE black
 Hardness: SH 57

30.8270

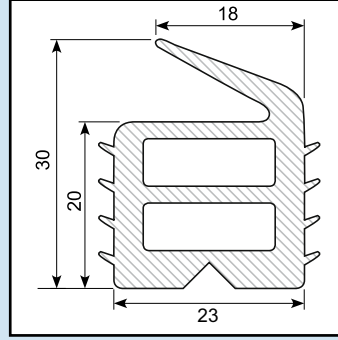

Material: EPDM black
 Hardness: SH 57

30.340

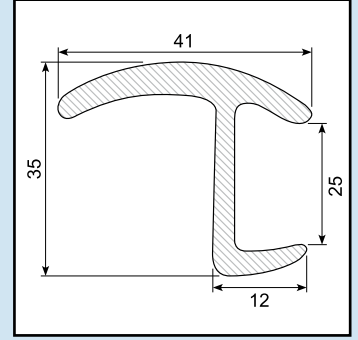

Material: EPDM black
 Hardness: SH 65
 Length: 3 m

30.2438

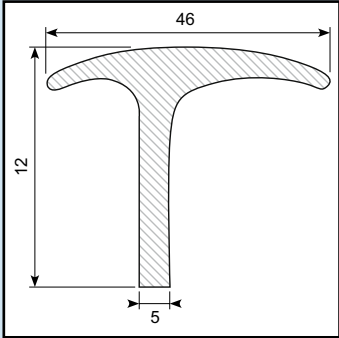

Material: EPDM black
 Hardness: SH 65
 Length: 2,2 m

30.7663

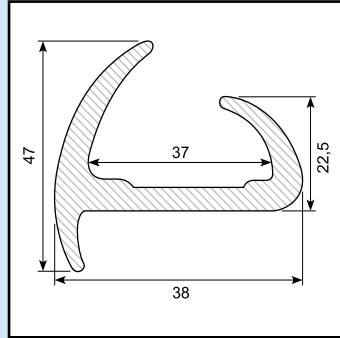

Material: EPDM black
 Hardness: SH 65
 Length: 5 m

54.710290

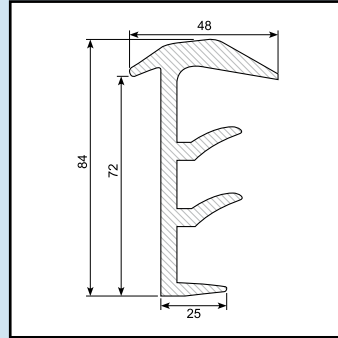

Material: EPDM black
 Hardness: SH 65
 Length: 10 m

30.315S

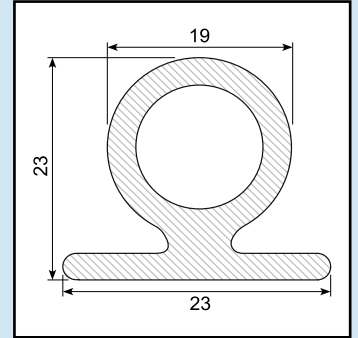

Material: EPDM black
 Hardness: SH 65
 Length: 10 m

30.315SB

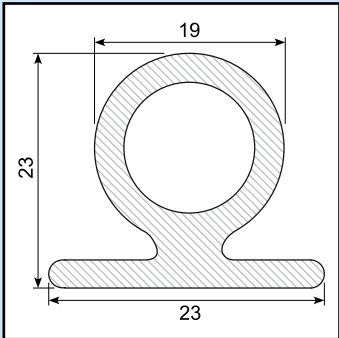

Material: EPDM black
 Hardness: SH 45
 Length: 10 m

30.7613

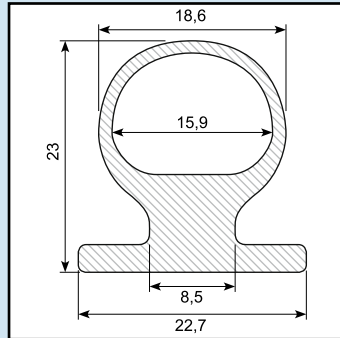

Material: EPDM black
 Hardness: SH 60

54.710700

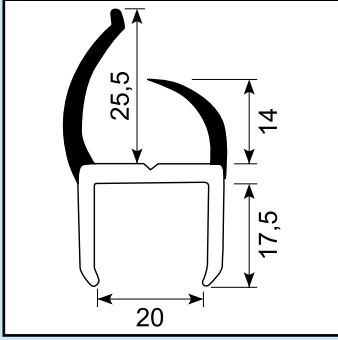

Material: PVC/PVC black/grey
 Hardness: Hard/soft
 Length: 3 m

54.710720

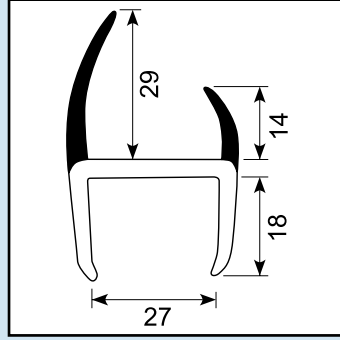

Material: PVC/PVC black/grey
 Hardness: Hard/soft
 Length: 3 m

54.710730

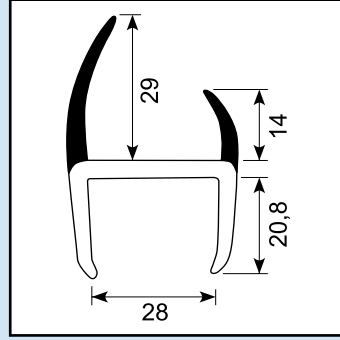

Co-ex profile 30 mm
 Grey
 Length: 3 m

54.710750

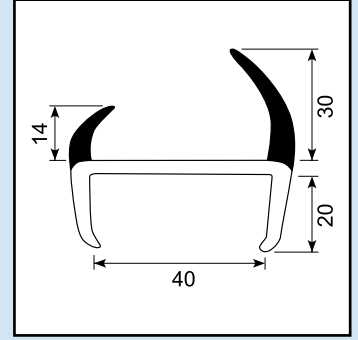

Material: PVC/PVC black/grey
 Hardness: Hard/soft
 Length: 3 m

54.710770

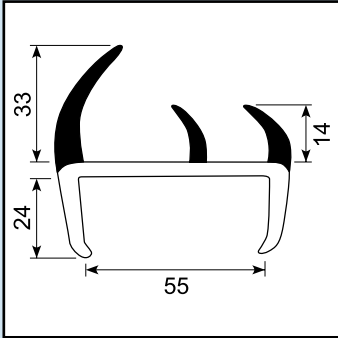

Co-ex profile 30 mm
 Grey
 Length: 3 m

54.710780

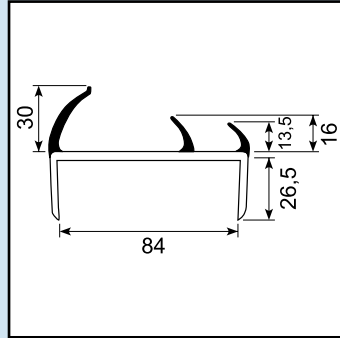

Material: PVC/PVC black/grey
 Hardness: Hard/soft
 Length: 3 m

50.083030

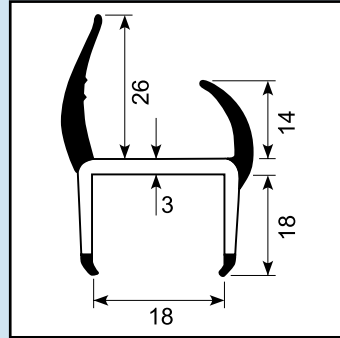

Co-ex profile 18 mm
 Black / white
 Length: 5 m
 With 4 soft lips

50.083032GG

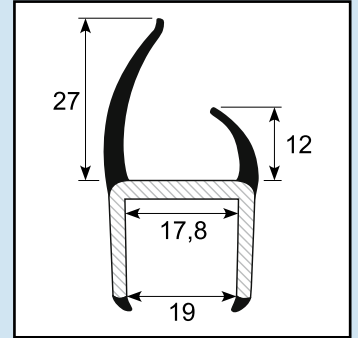

Co-ex profile 18,4 mm
 Grey / grey
 Length: 6 m
 With 4 soft lips

50.083033

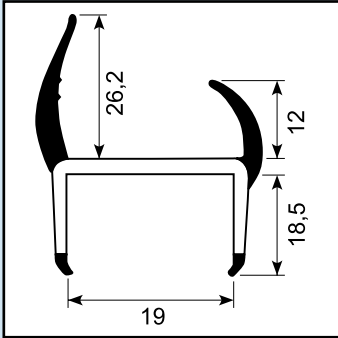

Co-ex profile 19 mm
 Light grey / black lips
 Length: 5 m

50.083040

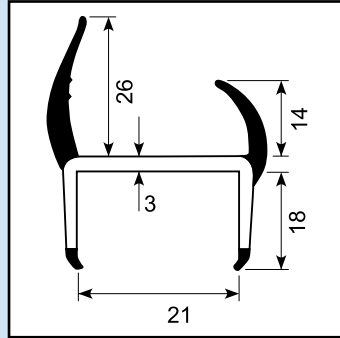

Co-ex profile 21 mm
 Black / white
 Length: 5 m
 With 4 soft lips

50.083040G

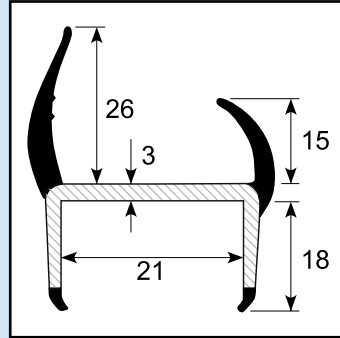

Co-ex profile 21 mm
 Black / grey
 Length: 6 m
 With 4 soft lips

50.083040GG

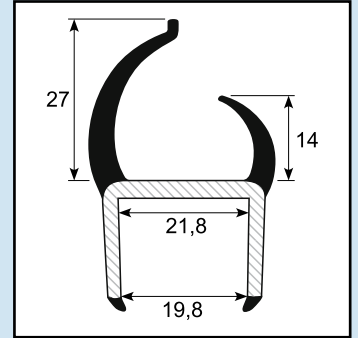

Co-ex profile 20,8 mm
 Grey / grey
 Length: 6 m
 With 4 soft lips

50.083040GL

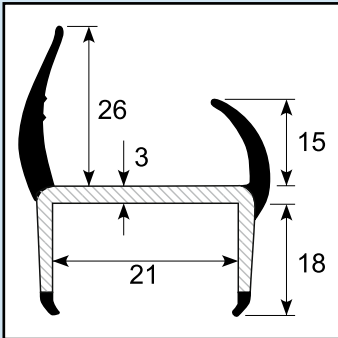

Co-ex profile 21 mm
 Light grey / light grey
 Length: 5 m
 With 4 soft lips

50.083045G

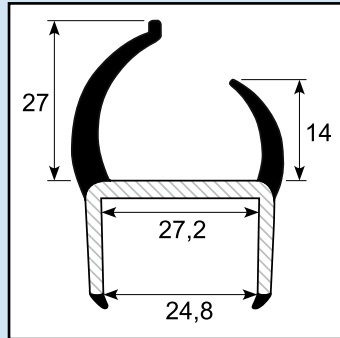

Co-ex profile 25 mm
 Grey / grey
 Length: 6 m
 With 4 soft lips

50.083050

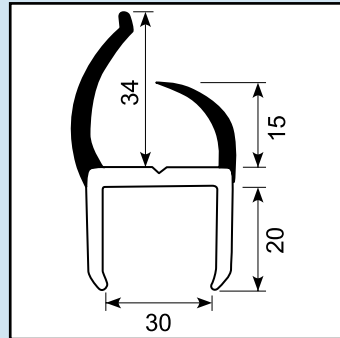

Co-ex profile 30 mm
 Black / white
 Length: 5 m
 With soft lips

50.083050G

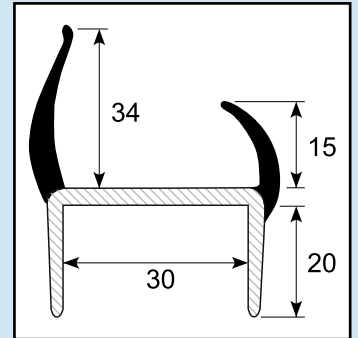

Co-ex profile 30 mm
 Black / light grey
 Length: 5 m
 With soft lips

50.083060

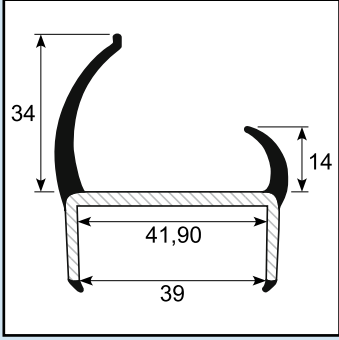

Co-ex profile 40 mm
White / black lips
Length: 5 m

50.083080G

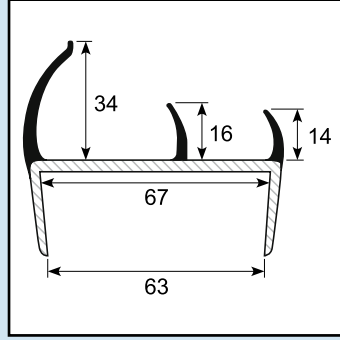

Co-ex profile 65 mm
Grey / grey lips
Length: 5 m

30.324S - 30.324SB

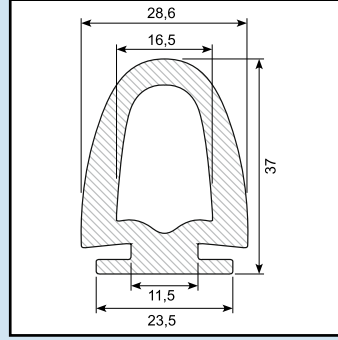

Material: EPDM black
Hardness: SH 65
Length: 5 m
30.324SB: SH 45

30.325S

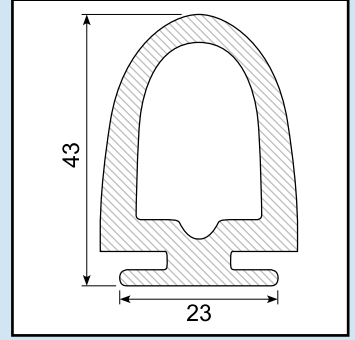

Material: EPDM black
Hardness: SH 65
Length: 5 m

30.330S

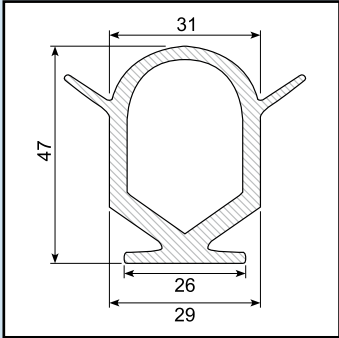

Material: EPDM black
Hardness: SH 65

30.331

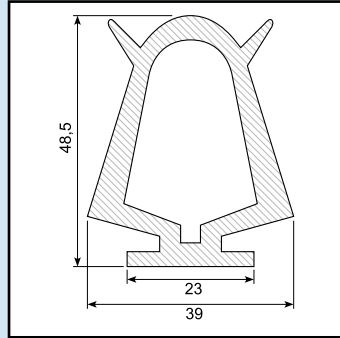

Material: EPDM black
Hardness: SH 70

30.7935

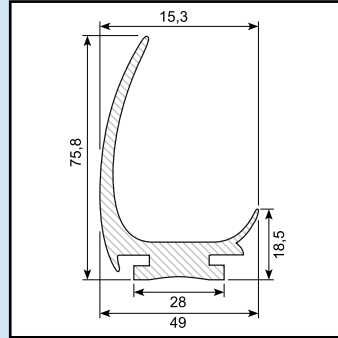

Material: EPDM black
Hardness: SH 65
Length: 2,8 m

30.144

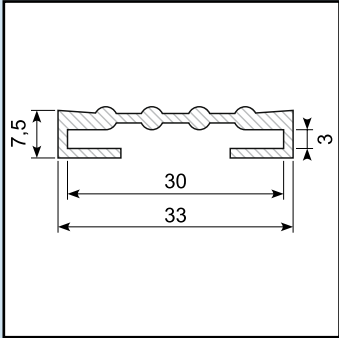

Material: EPDM black
Hardness: SH 45

31.4281

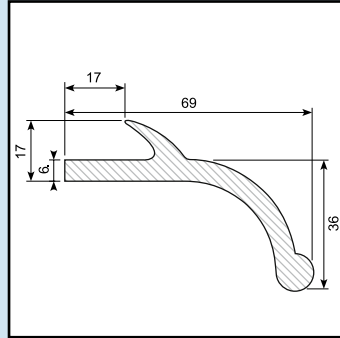

Material: EPDM black
Hardness: SH 85
Length: 2,7 m

30.798

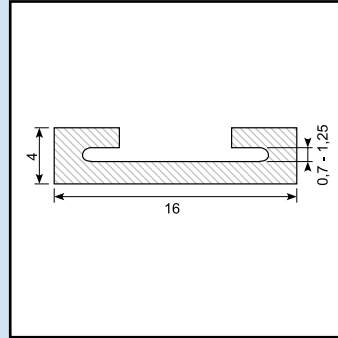

Material: EPDM black
Hardness: SH 65

30.141

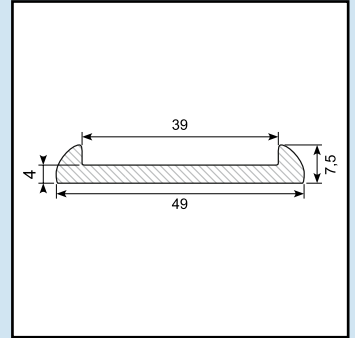

Material: CR black
Hardness: SH 65

30.142S

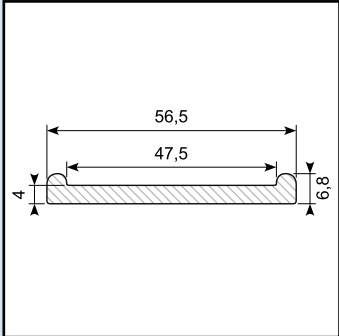

Material: EPDM black
Hardness: SH 65

30.143S

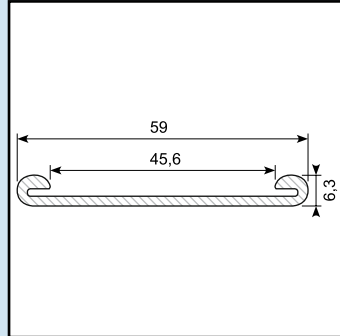

Material: EPDM black
Hardness: SH 65

30.145

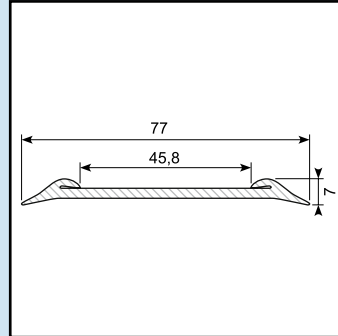

Material: EPDM black
Hardness: SH 70

31.145W

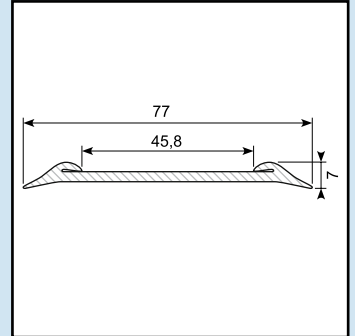

Material: EPDM white
Hardness: SH 65

31.048

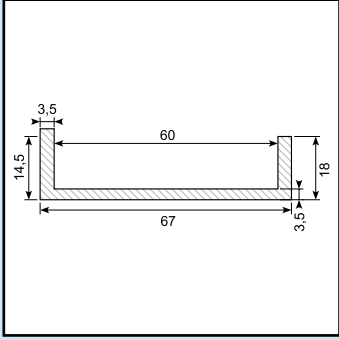

Material: EPDM black
Hardness: SH 65

30.8331

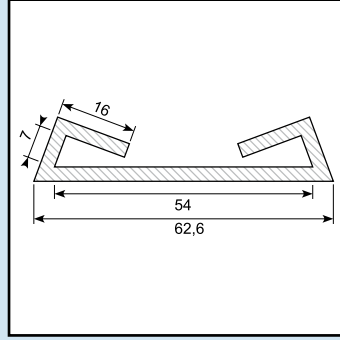

Material: EPDM black
Hardness: SH 65

41.671

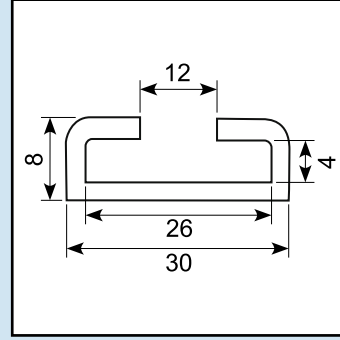

Material: Aluminium
Length: 1 m

41.672

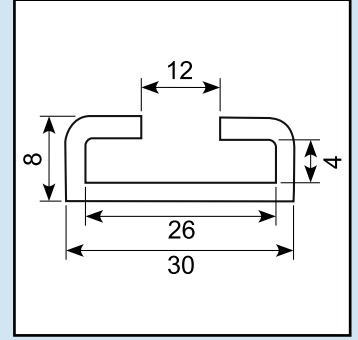

Material: Aluminium
Length: 2 m

41.675

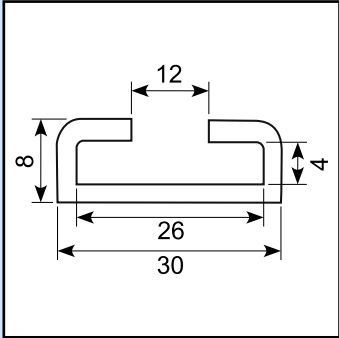

Material: Aluminium
Length: 5 m

32.8520

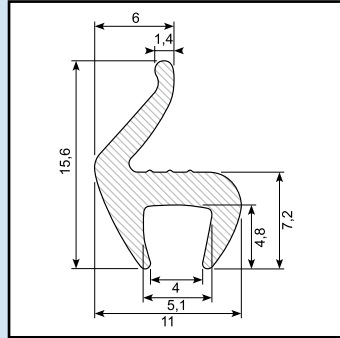

Universal end-stop profile
Roll of 50 m
15,6 x 11 mm

32.8519

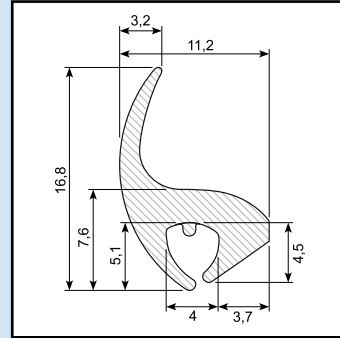

End-stop profile
Roll of 50 m
Height 16 mm

32.8516

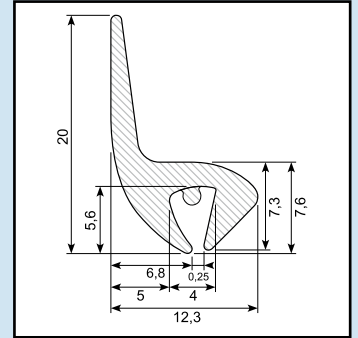

End-stop profile
Roll of 50 m
Height 19 mm

32.8517

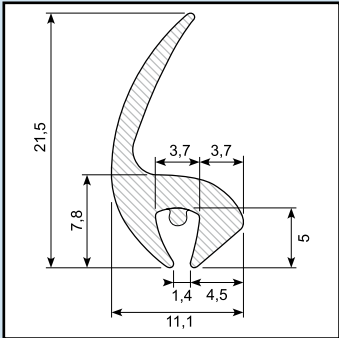

End-stop profile
Roll of 50 m
Height 25 mm

32.8518

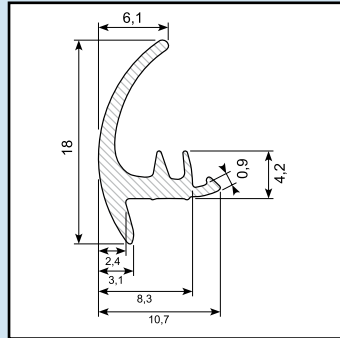

End-stop profile
Roll of 50 m

31.368

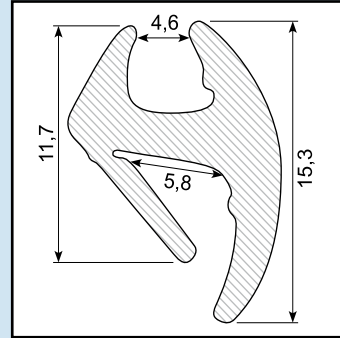

End-stop profile
Material: EPDM black
Hardness: SH 65

31.369

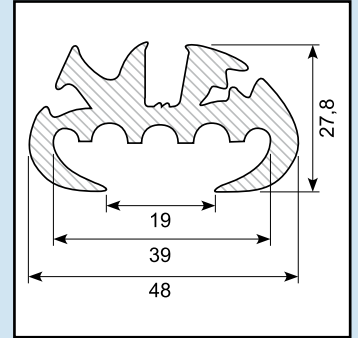

End-stop profile
Material: EPDM black
Hardness: SH 65

30.7649

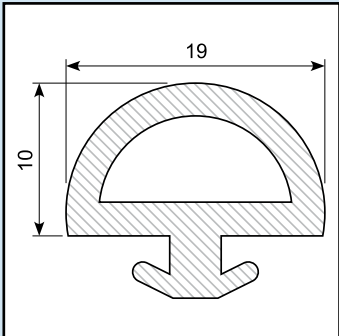

D-weatherstrip
Material: EPDM
Hardness: SH 60

30.7933

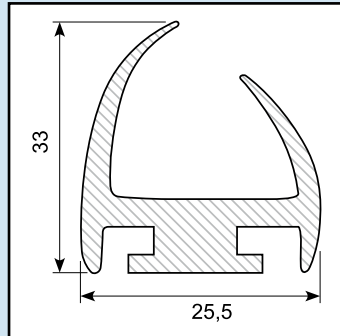

H-profile for aluminium rail
Material: EPDM
Hardness: SH70

30.8469

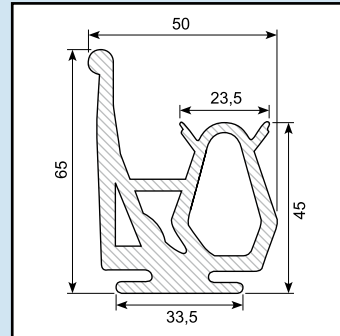

Rubber profile with drip cap
For loading tail board
Material: EPDM
Hardness: SH 67
Length: 8 m

30.6648

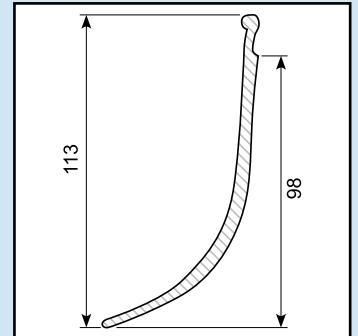

Skirt profile
Hardness: SH 75

30.2151

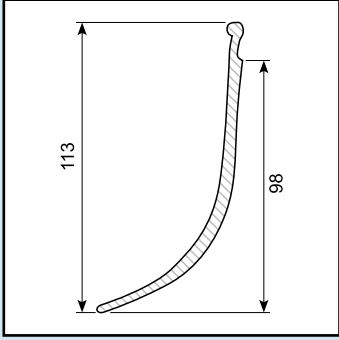

Skirt profile
Material: PVC white
Roll of 14 m

30.2566

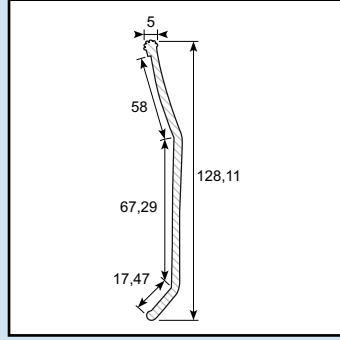

Skirt profile
Material: PVC black
Hardness: SH 80
Height: 125 mm
Length: 1 m
Roll of 64 m

30.314S

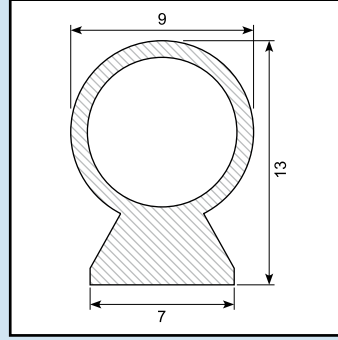

Rubber profile
Material: EPDM
Hardness: SH 60 / 65

45.224

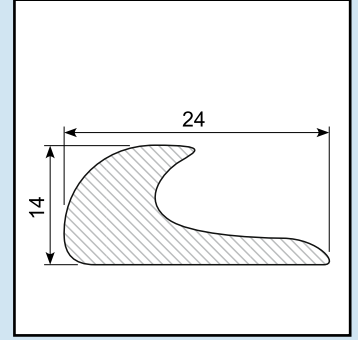

Drip moulding
Height: 24 mm

30.7651

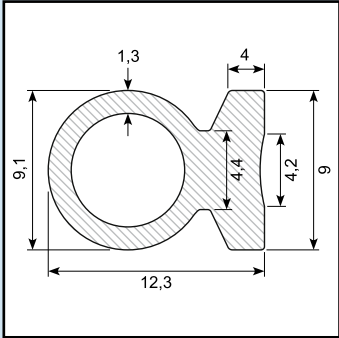

Balloon profile
Hardness: SH 65

30.7652

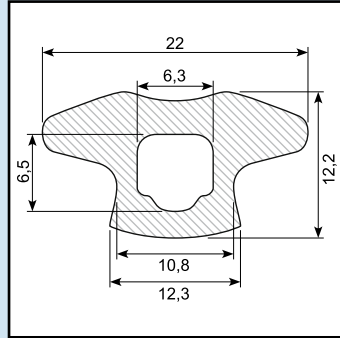

Rubber profile
Material: EPDM
Hardness: SH 65

30.313

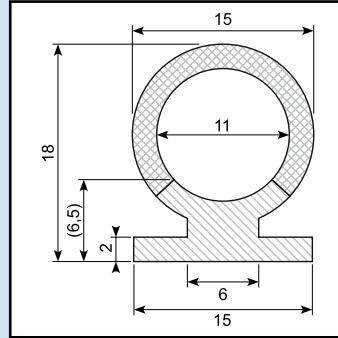

Co-ex profile
Material: EPDM / sponge rubber
Hardness: SH 80

30.7650

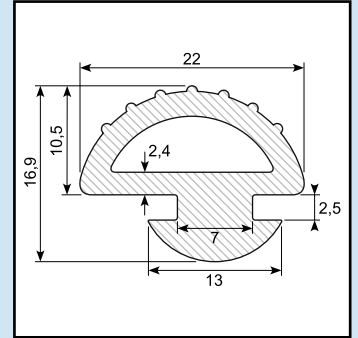

D-weatherstrip
Material: EPDM
Hardness: SH 70

39.1208P

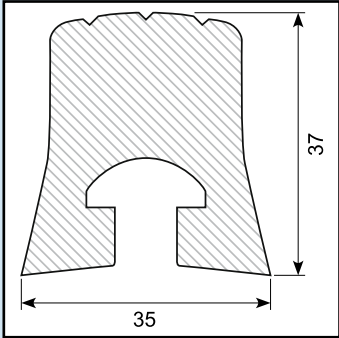

Fender profile with channel
Material: PE
Length: 3 m

30.7932

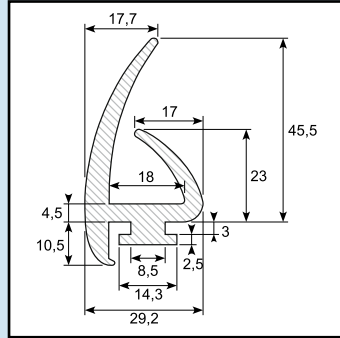

Rubber profile for alu. track
Material: EPDM
Hardness: SH 70

41.333S

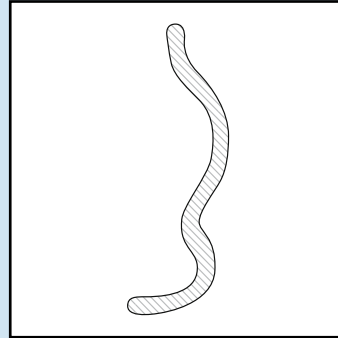

Steel profile for mounting of rubber profile 30.333
Length: 2,6 m

30.333

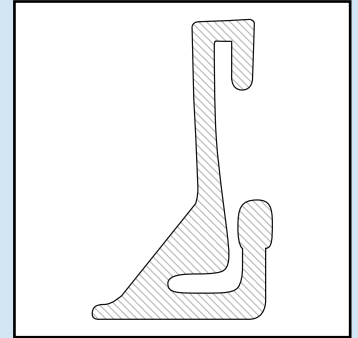

L-profile
Material: EPDM
Hardness: SH 70
Roll of 50 m

30.2984-1

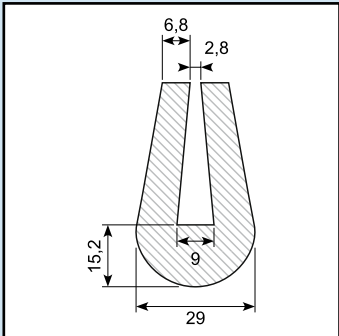

U-profile
Material: EPDM
Hardness: SH 70
Roll of 25 m

30.2984-2

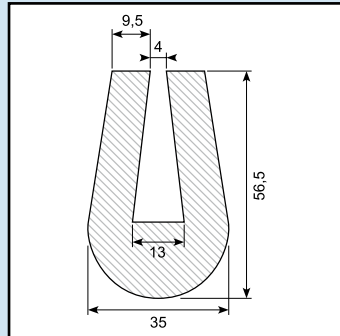

U-profile
Material: EPDM
Hardness: SH 65
Roll of 25 m

30.2984-3

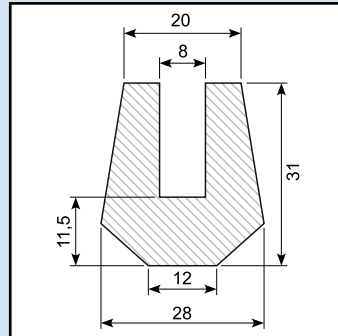

U-profile
Material: EPDM
Hardness: SH 70
Roll of 25 m

30.2984-5

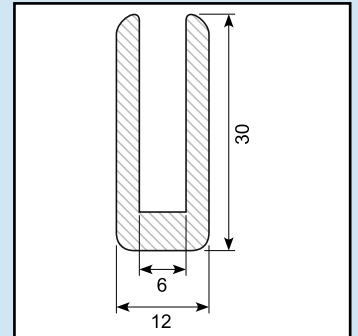

U-profile
Material: EPDM
Hardness: SH 70

30.2984-6

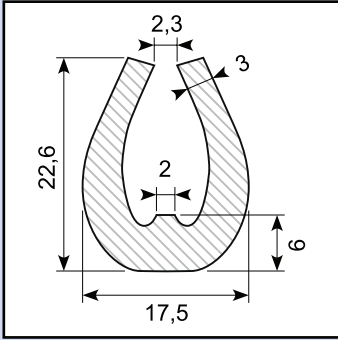

U-profile
Material: EPDM
Hardness: SH 80
Roll of 50 m

30.13447-6

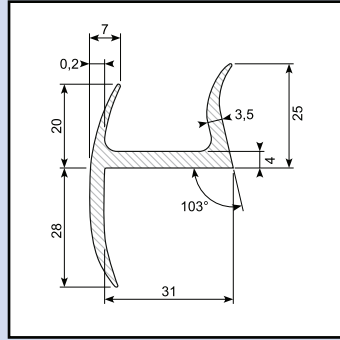

Container profile
Material: EPDM
Hardness: SH 70
Length: 2,5 m

30.13447-7

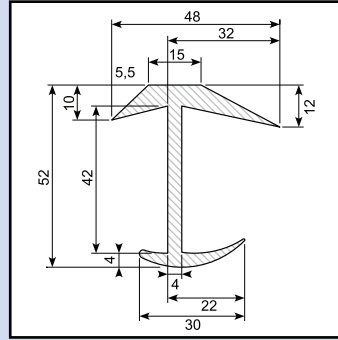

Container profile
Material: EPDM
Hardness: SH 70
Length: 2,5 m

30.13447-8

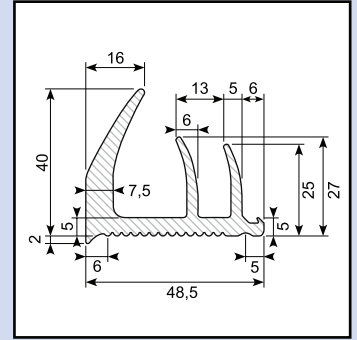

Container profile
Material: EPDM
Hardness: SH 70
Length: 2,5 m

30.13447-1

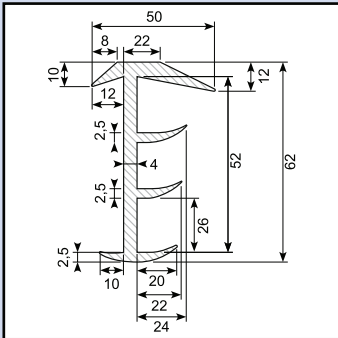

Container profile
Material: EPDM
Hardness: SH 70
Length: 2,5 m

30.13447-2

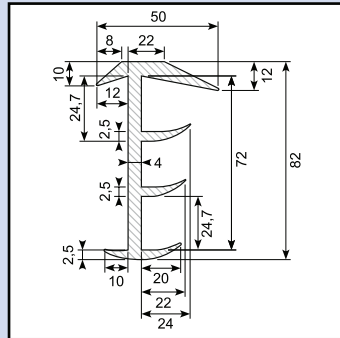

Container profile
Material: EPDM
Hardness: SH 70
Length: 2,5 m

30.13447-3

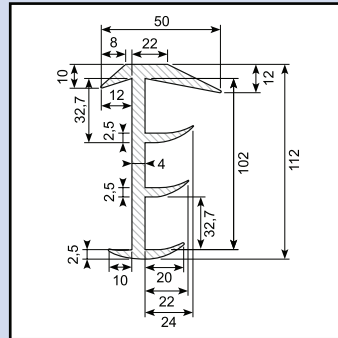

Container profile
Material: EPDM
Hardness: SH 70
Length: 2,5 m

BIBUS[®]
SUPPORTING YOUR SUCCESS

BIBUS SK, s.r.o
Trnavská 31, SK-94 901 Nitra

Tel.: 037/ 7777 911 Email: sale@bibus.sk
Fax.: 037/ 7777 999 http://www.bibus.sk