

moviroll

BATTERY ROLL PUSHERS



MORE PRODUCTIVITY, HIGHER SAFETY LEVEL

Moviroll roll pushers improve the productivity and increase the safety level as they allow the operator to effortlessly and safely maneuver both large and small cylindrical loads. Moviroll reduces risks for the operator according to the Technical Standards ISO 11228 "Ergonomics Manual handling".

They are ideal to move paper and tissue rolls, wire and cable reels and drums as well as vehicles, but they are also used to move loads in several other industrial applications.

Battery roll pushers offer the advantage of free movement without the constraints of the pneumatic connections or electrical cables. They are powered by high performance and plug&play 24 V or 48 V lithium battery.

VARIABLE SPEED

to suit any operator needs

FORWARD AND REVERSE GEAR

two separated and intuitive buttons shielded from dirt, dust and water

OVERSIZED WHEELS

to easily overcome any obstacles along the way

CHARGE STATUS INDICATOR

easily see when the battery needs to be recharged

CUT FRAMES

for an easy removal of the roller and roller bearings

ECO-FRIENDLY BATTERY

highest quality plug&play lithium battery

MRE LP

MRE LP is designed for special applications both in the paper and automotive industries.

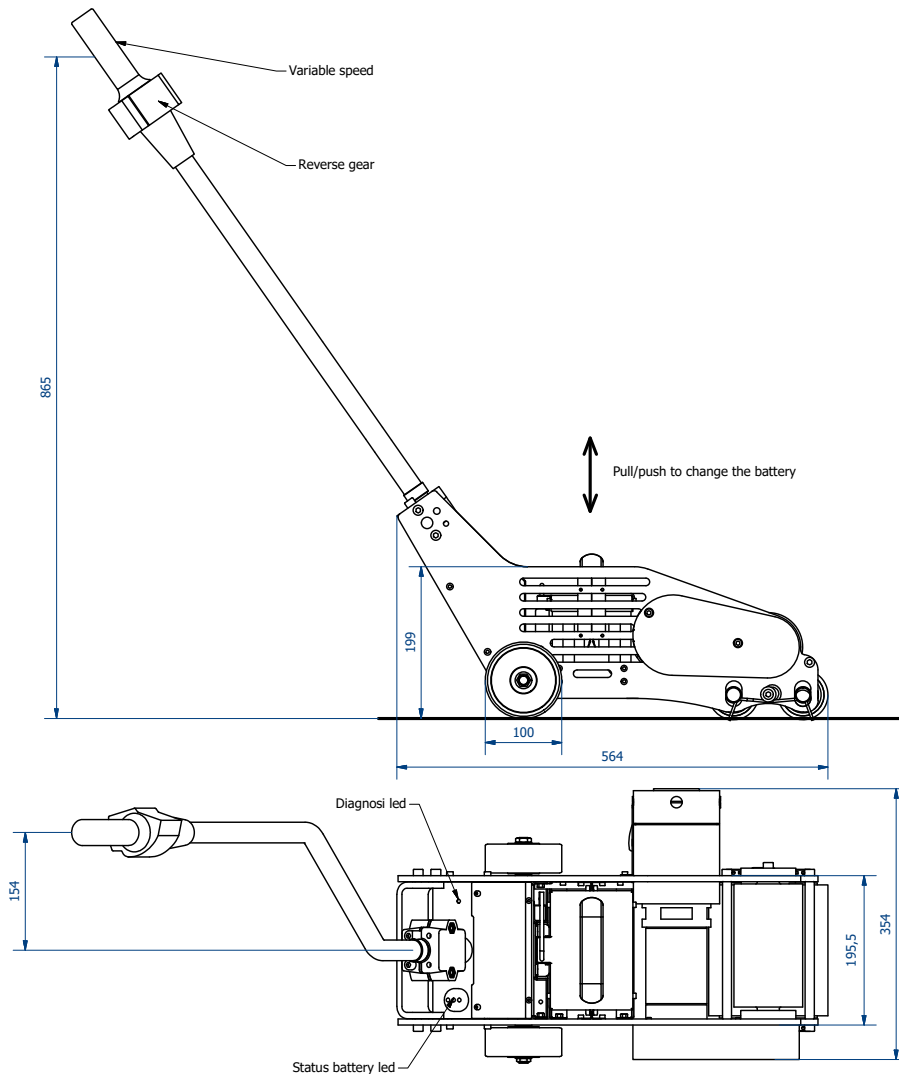

model	thrust force		lift force	max rolls diameter	motor	battery	max speed	unit weight
	paper	vehicles						
MRE100 LP	12000 kg	8000 kg	3000 kg	4500 mm	24VDC IP44	lithium 24 V	13 m/min	36 kg
MRE 200 LP	16000 kg	10000 kg	3500 kg	4500 mm	24VDC IP44	lithium 24 V	10 m/min	36 kg
MRE 300 LP	20000 kg	15000 kg	4000 kg	4500 mm	24VDC IP44	lithium 24 V	8 m/min	36 kg