



QDE3GL

PROPORTIONAL COMPENSATED FLOW CONTROL VALVE WITH INTEGRATED ELECTRONICS

SUBPLATE MOUNTING
ISO 6263-03

p max 250 bar
Q max 40 l/min

OPERATING PRINCIPLE

- QDE3GL are proportional pressure-compensated flow control valves with on-board electronics and mounting surface according to ISO 6263-03. Depending on the presence of the P port in the mounting surface, they can operate as either 2- or 3-port flow control valves.
- These valves are suitable for controlling flow in sub-systems of a hydraulic circuit or for controlling the speed of a hydraulic cylinder.
- These valves are equipped with compact integrated electronics, with analogue or fieldbus (IO-Link or CAN Open) interface.
- QDE3GL valves are available in four flow adjustment ranges of up to 40 l/min.

PERFORMANCES

(values measured with viscosity of 36 cSt at 50 °C with electronic control unit)

Maximum operating pressure	bar	250			
Controlled flow (Q _B)	l/min	14	20	30	40
Max inlet flow (Q _A) (3-port)	l/min	40	50	40	50
Spring setting in pressure compensator	bar	4	8	4	8
Minimum pressure drop A > B	bar	10	22	10	22
Hysteresis	% of Q _{max}	< 6 %			
Repeatability	% of Q _{max}	< ± 1,5 %			
Electrical characteristics	see point 4				
Ambient temperature range	°C	-20 / +60			
Fluid temperature range	°C	-20 / +80			
Fluid viscosity range	cSt	10 ÷ 400			
Fluid contamination degree	according to ISO 4406:1999 class 18/16/13				
Recommended viscosity	cSt	25			
Mass	kg	1,6			

HYDRAULIC SYMBOLS

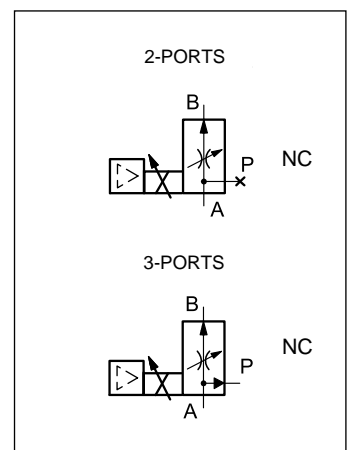

1 - IDENTIFICATION CODE

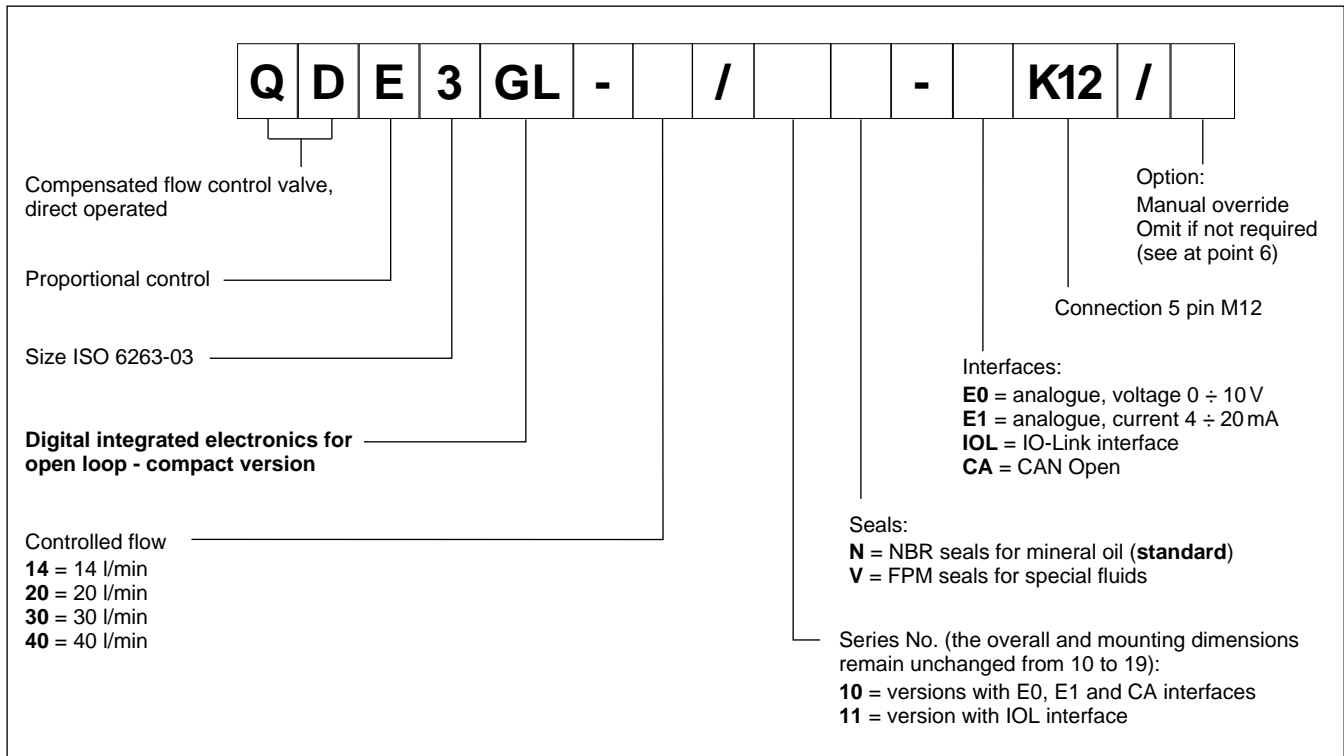

2 - CONFIGURATIONS AND MOUNTING INTERFACE

The two- or three-port function is achieved by drilling the mounting interface with holes according to ISO 6263-03. The T path to the reservoir is not created, and the P path is created in the case of a three-ports configuration only.

Alternatively, in order to use the QDE3GL valve in the two-ports configuration, it is possible to interpose an adapter plate with plug (codes 0113388 and 0530384 respectively), which must be ordered separately.

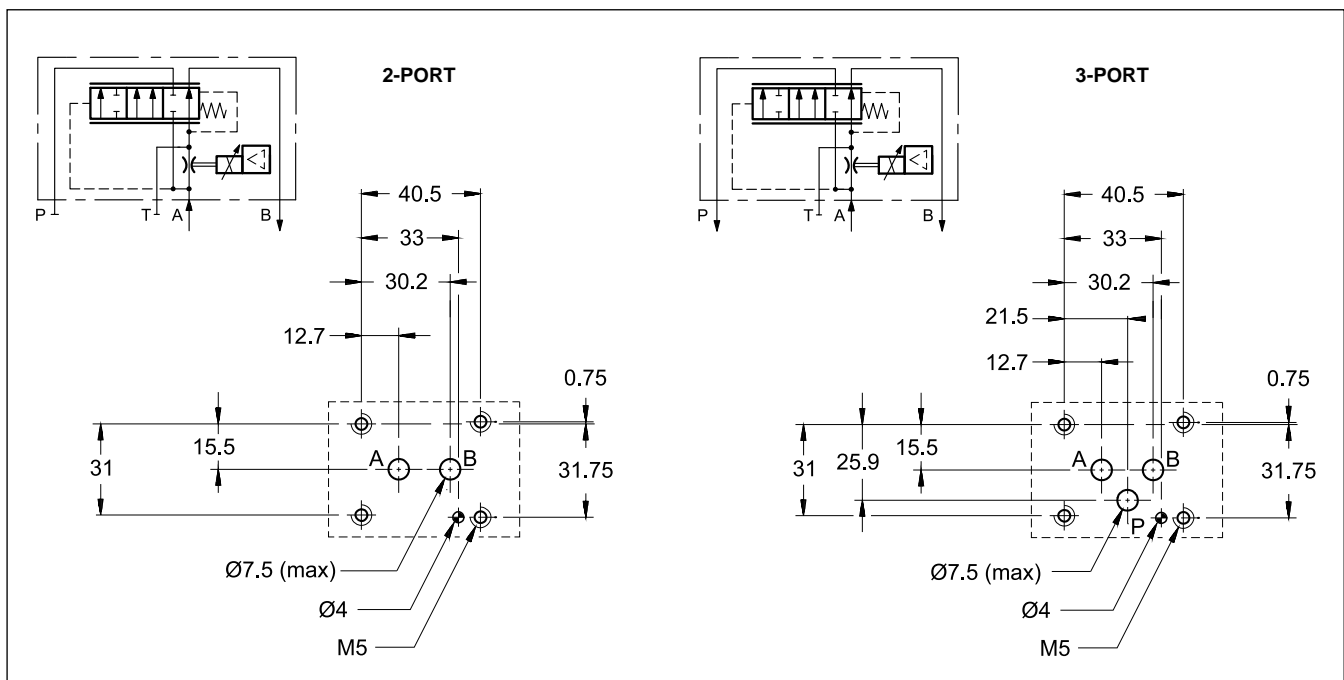

3 - CHARACTERISTIC CURVES

(obtained with viscosity of 36 cSt a 50 °C)

3.1 - Two-port

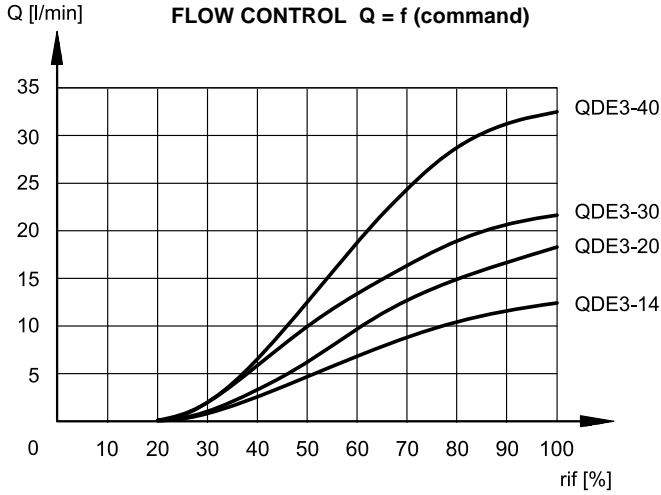

Typical flow rate characteristics A → B for sizes 14 - 20 - 30 - 40 l/min as function of the command signal.

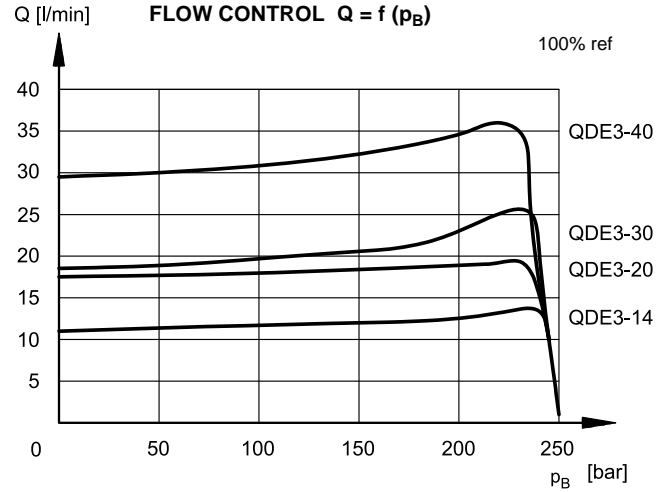

3.2 - Three-port

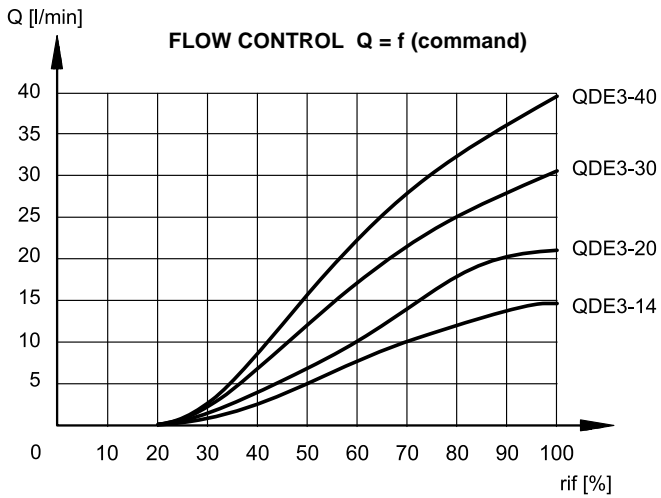

Typical flow rate characteristics A → B for sizes 14 - 20 - 30 - 40 l/min as function of the command signal.

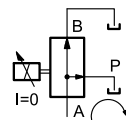
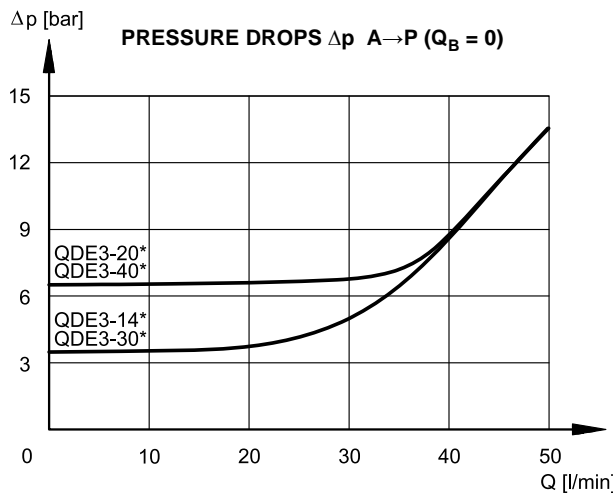
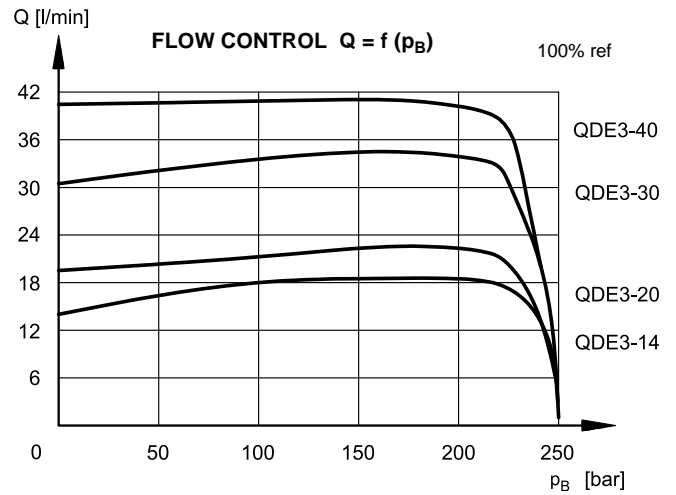

Pressure drops with flow A→P. Obtained with $Q_B = 0$ (no current)

4 - ELECTRICAL CHARACTERISTICS

Duty cycle		100% (continuous operation)
Protection class according to EN 60529		IP65 / IP67 (NOTE)
Supply voltage	V DC	24 (from 19 to 30 VDC), ripple max 3 Vpp
Power consumption	VA	25
Maximum solenoid current	A	1.88
Fuse protection, external	A	2A time lag
Managed breakdowns		overload and electronics overheating, cable breakdown, supply voltage failures
Electromagnetic compatibility (EMC) emissions EN 61000-6-4, immunity EN 61000-6-2		according to 2014/30/EU standards
Command signal: voltage (E0) current (E1)	V DC mA	0 ÷ 10 (impedance Ri > 11 kOhm) 4 ÷ 20 (impedance Ri = 58 Ohm)
Monitor signal (current to solenoid): voltage (E0) current (E1)	V DC mA	0 ÷ 5 (impedance Ro > 1 kOhm) 4 ÷ 20 (impedance Ro = 500 Ohm)
IO-Link communication (IOL): Data rate	kBaud	IO-Link Port Class B 230,4
Can Open communication (CA): Data rate	kbit	10 ÷ 1000
Data register (IOL and CA versions only)		solenoid voltage supply, solenoid faults (shortcircuit, bad config, internal), box temperature, switch-on time, vibrations
Connection		5-pin M12 code A (IEC 61076-2-101)

NOTE: The IP degree is guaranteed only with mating connector of equivalent IP degree, installed and tightened correctly.

In IO-Link networks, the length of the connecting cables is limited to 20 metres. In CA versions, pin 3 and pin 5 are galvanic isolated up to 100 V to avoid earth loops.

4.1 - Pin tables

'E0' connection



Pin	Values	Function
2	24 V DC	Supply voltage (solenoid and logic)
5	0 V	
1	0 ÷ 10 V	Command
3	0 V	Command reference
4	0 ÷ 5 V	Monitor (0V reference: pin 5)

'E1' connection



Pin	Values	Function
2	24 V DC	Supply voltage (solenoid and logic)
5	0 V	
1	4 ÷ 20 mA	Command
3	0 V	Command reference
4	4 ÷ 20 mA	Monitor (0V reference: pin 5)

'IOL' connection

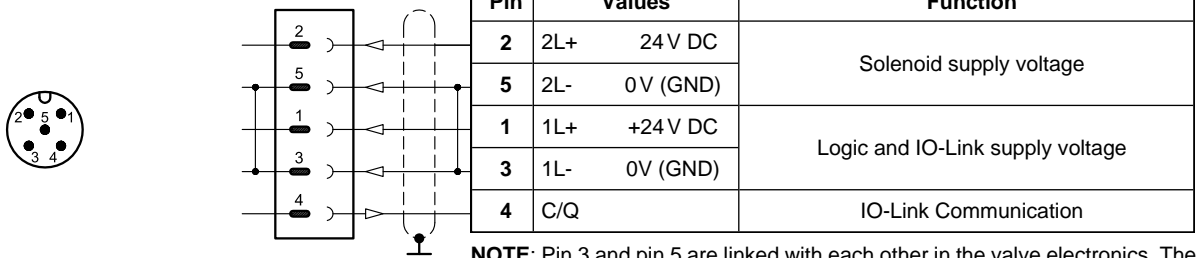

NOTE: Pin 3 and pin 5 are linked with each other in the valve electronics. The reference potentials 1L- and 2L- of the two supply voltages must also be linked with each other on the customer side.

'CA' connection

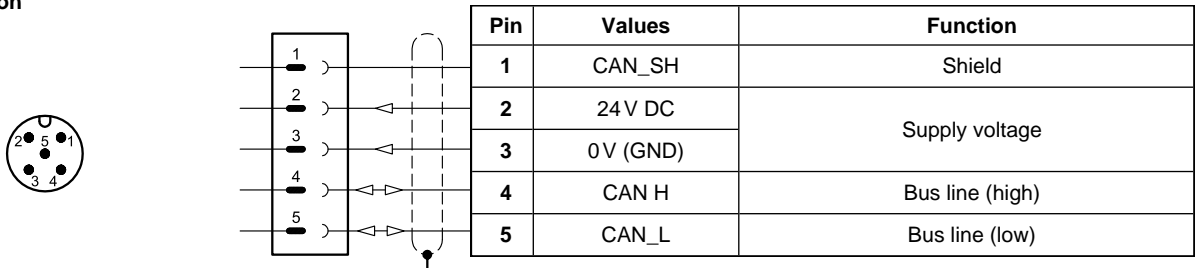

5 - OVERALL AND MOUNTING DIMENSIONS

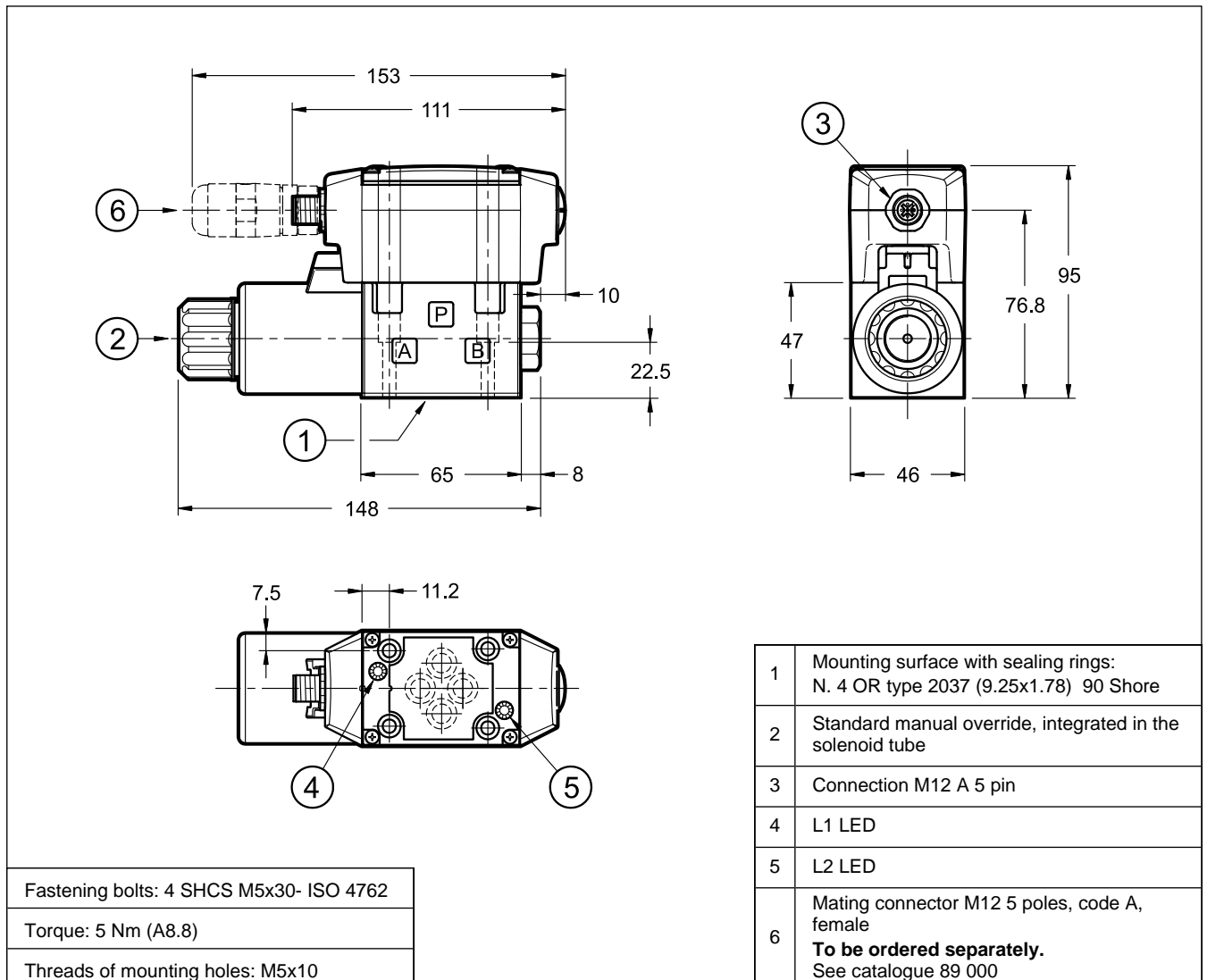

Fastening bolts: 4 SHCS M5x30- ISO 4762
Torque: 5 Nm (A8.8)
Threads of mounting holes: M5x10

6 - MANUAL OVERRIDE

Standard valves have the pin for the manual operation integrated in the solenoid tube. The operation of this override must be executed with a suitable tool, minding not to damage the sliding surface.

Available manual overrides are:

- CM : manual override boot protected.
- CK1 version, knob.

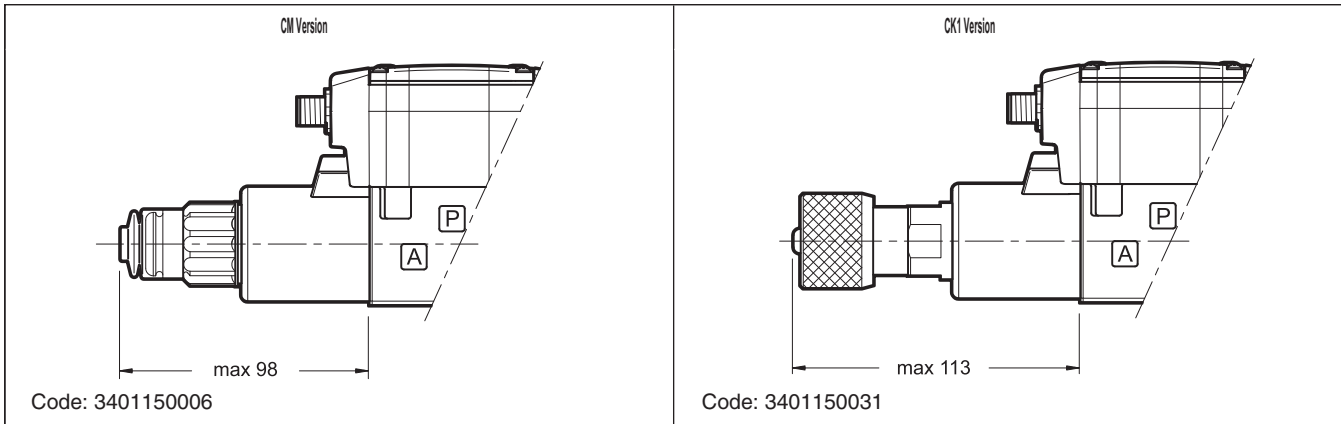

7 - HYDRAULIC FLUIDS

Use mineral oil-based hydraulic fluids HL or HM type, according to ISO 6743-4. For these fluids, use NBR seals (code N). For fluids HFDR type (phosphate esters) use FPM seals (code V). For the use of other kinds of fluid such as HFA, HFB, HFC, please consult our technical department. Using fluids at temperatures higher than 80 °C causes a faster degradation of the fluid and of the seals characteristics.

The fluid must be preserved in its physical and chemical characteristics.

8 - INSTALLATION

The QDE3GL valves can be installed in any position without impairing correct operation. Ensure that there is no air in the hydraulic circuit.

Valves are fixed by means of screws or tie rods on a flat surface with planarity and roughness equal to or better than those indicated in the relative symbols.

If minimum values are not observed fluid can easily leak between the valve and support surface.

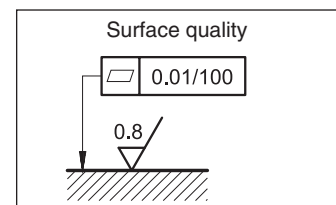

9 - ACCESSORIES

(to be ordered separately)

9.1 - Mating connectors

Mating connectors must be ordered separately. See catalogue 89 000.

9.2 - Mating connectors and caps for Fieldbus communication and for sensors.

Duplomatic offers spare parts to be wired and also ready-to-use cord sets. Please refer to cat. 89 000.

9.3 - Connection cable

The optimal wiring provides for 7 isolated conductors, with separate screen for the signal wires (command, monitor) and an overall screen.

Cross section for power supply:

- up to 20 m cable length : 1,0 mm²
- up to 40 m cable length : 1,5 mm² (IO-Link excluded)

Cross section for signals (command, monitor):

- 0,50 mm²

9.4 - Kit for start-up LINPC-USB

Device for service start-up and diagnostic. See catalogue 89 850.

BIBUS
SUPPORTING YOUR SUCCESS

BIBUS SK, s.r.o
Trnavská 31, SK-94 901 Nitra

Tel.: 037/ 7777 911 Email: sale@bibus.sk
Fax.: 037/ 7777 999 http://www.bibus.sk