

ELECTROMECHANICAL CYLINDERS

SERIES 6E

Sizes 32, 40, 50, 63, 80, 100

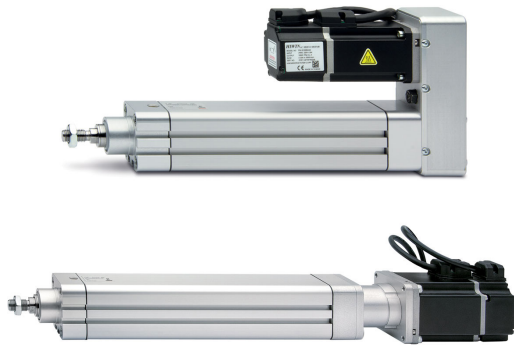

- In compliance with the ISO 15552 standard
- Multi-position system with transmission of the movement by means of a recirculating ball screw
- Possibility to connect the motor in line or parallel
- Large range of motor interfaces
- Permanent pre-lubrication (maintenance free)
- High positioning repeatability
- Reduced axial backlash
- Possibility to use magnetic sensors
- Integrated anti-rotation system of the rod
- IP65
- Wide range of fixing accessories

The Series 6E cylinders are mechanical linear actuators with rod, in which the rotary movement, generated by a motor, is converted into a linear movement by means of a recirculating ball screw. Available in 6 sizes, the Series 6E has dimensions based on the ISO 15552 standard and it is therefore possible to use the mounting accessories of the pneumatic cylinders.

The cylinders are equipped with a magnet that makes it possible to use external magnetic proximity switches (Series CST and CSH), allowing operations like homing or extra-stroke readings to be performed. The Series 6E is equipped with specific interface kits, which make it possible to connect the motor, both in line and parallel. High precision and easy mounting make the Series 6E the ideal solution for different applications, especially for multi-position systems.

GENERAL DATA

Construction	electromechanical cylinder with recirculating ball screw
Design	profile with thread rolling screws based on the ISO 15552 standard
Operation	multi-position actuator with high precision linear movement
Sizes	32, 40, 50, 63, 80, 100
Strokes min - max	100 ÷ 1500 mm
Anti-rotation function	with anti-friction pads in technopolymer
Mounting	front / rear flange, with feet, with front / rear / swivel trunnion
Mounting motor	in line and parallel
Operating temperature	0°C ÷ 50°C
Storage temperature	-20°C ÷ 80°C
Protection class	IP40 / IP65
Lubrication	not necessary. A pre-lubrication is performed on the cylinder.
Max. Reversing backlash	0,02 mm
Repeatability	± 0,02
Duty cycle	100%
Max rotation play	± 0,4°
Use with external sensors	nlots on three sides for sensors model CSH and CST

ELECTROMECHANICAL CYLINDERS
SERIES 6E - CODING EXAMPLE
CODING EXAMPLE

6E	032	BS	0200	P05	A	P
6E	SERIES					
032	SIZE 032 = 32 040 = 40 050 = 50				063 = 63 080 = 80 100 = 100	
BS	TRANSMISSION BS = recirculating ball screw					
0200	STROKE 100 ÷ 1500 mm					
P05	SCREW PITCH P05 = 5 mm P10 = 10 mm P16 = 16 mm (for size 40 only) P20 = 20 mm (for size 50, 80, 100 only)				P25 = 25 mm (for size 63 only) P32 = 32 mm (for size 80 only) P40 = 40 mm (for size 100 only)	
A	CONSTRUCTION A = standard with rod nut					
P	VERSION P = IP65 (_ _ _) = extended piston rod _ _ _ mm					

ELECTRIC ACTUATION

2
MECHANICAL CHARACTERISTICS

Size		32	32	40	40	40	50	50	50	63	63	63	80	80	80	80	100	100	100	100
BS screw pitch "P"	[mm]	5	10	5	10	16	5	10	20	5	10	25	5	10	20	32	5	10	20	40
Dynamic load coefficient "C"	[N]	6600	4400	12000	8500	9150	14900	11300	7800	17700	20500	11300	26300	52500	28200	26100	35100	55900	45300	55900
Average load ^(A)	[N]	525	440	950	850	1070	1180	1130	980	2050	1535	2085	5250	3550	3845	2785	5590	5705	8875	8875
Maximum force ^(B)	[N]	1075	1075	3360	3360	3360	5440	5440	5130	8400	8400	6187	12600	12600	12600	18000	18000	18000	18000	18000
Max applicable torque to screw's shaft	[Nm]	0,95	1,90	2,97	5,94	9,51	4,81	9,62	18,14	7,43	14,85	27,35	11,14	22,28	44,56	71,30	15,92	31,83	63,66	127,32
Max linear cylinder's speed ^(B)	[m/s]	0,56	1,12	0,42	0,84	1,33	0,33	0,67	1,33	0,27	0,53	1,33	0,23	0,47	0,94	1,5	0,19	0,38	0,75	1,05
Max rotational cylinder's speed	[rpm]	6670	6670	5000	5000	5000	4000	4000	4000	3200	3200	3200	2810	2810	2810	2810	2250	2250	2250	2250
Max cylinder's acceleration	[m/s ²]	25	25	25	25	25	25	25	25	25	25	25	25	25	25	25	25	25	25	25
Minimum stroke	[mm]	15	25	15	25	40	15	25	50	15	25	65	15	25	50	80	15	25	50	100
Maximum stroke	[mm]	500	500	700	700	700	1000	1000	1000	1200	1200	1200	1500	1500	1500	1500	1500	1500	1500	1500
Mass of actuator, stroke zero	[kg]	1,18	1,18	1,40	1,40	1,40	2,28	2,28	2,28	3,5	3,5	3,5	6,44	6,44	6,44	6,44	10,73	10,73	10,73	10,73
Mass of actuator, variable with stroke	[kg/mm]	3,77E03	3,77E03	5,30E03	5,30E03	5,30E03	6,30E03	6,30E03	6,30E03	9,77E03	9,77E03	9,77E03	1,37E02	1,37E02	1,37E02	1,37E02	2,05E02	2,05E02	2,05E02	2,05E02
MOVING MASSES AND INERTIA																				
Inertia, stroke zero "I _f "	[kg·cm ²]	0,029	0,029	0,079	0,079	0,079	0,218	0,218	0,218	0,664	0,664	0,664	2,309	2,309	2,309	2,309	5,265	5,265	5,265	5,265
Inertia, variable with stroke "K _v "	[kg·cm ² /mm]	2,00E04	2,00E04	5,00E04	5,00E04	5,00E04	1,20E03	1,20E03	1,20E03	3,00E03	3,00E03	3,00E03	8,10E03	8,10E03	8,10E03	8,10E03	1,98E02	1,98E02	1,98E02	1,98E02
Sliding mass, stroke zero "m _{cs} "	[kg]	0,15	0,15	0,43	0,43	0,43	0,70	0,70	0,70	1,07	1,07	1,07	2,25	2,25	2,25	2,25	3,94	3,94	3,94	3,94
Sliding mass, variable with stroke "K _v "	[kg/mm]	7,90E04	7,90E04	9,88E04	9,88E04	9,88E04	1,14E03	1,14E03	1,14E03	1,38E03	1,38E03	1,38E03	1,88E03	1,88E03	1,88E03	1,88E03	2,37E03	2,37E03	2,37E03	2,37E03

^(A)Value refers to a covered distance of 10000 Km (see the diagrams "Life of the cylinder according to the average axial force applied").

^(B)The maximum speed and the maximum force of cylinder change according to its stroke (see the diagrams "maximum speed of cylinder according to its stroke" and "maximum force of cylinder according to its stroke").

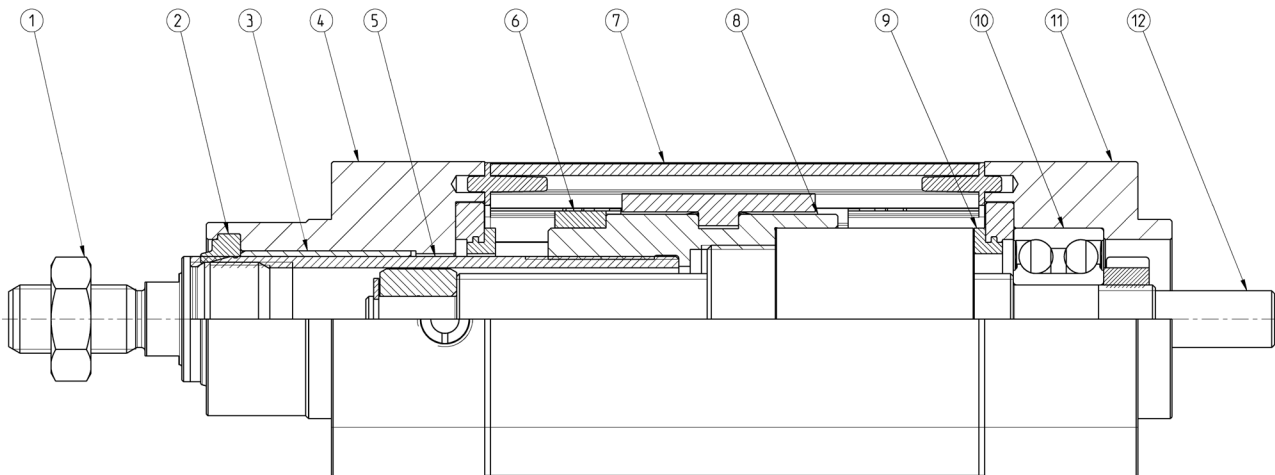
SERIES 6E MATERIALS

PARTS	MATERIALS
1. Rod nut	Zinc-plated steel
2. Rod seal	PU
3. Bushing	Technopolymer
4. Front endcap	Anodized aluminium alloy
5. Rod	Stainless steel
6. Magnet	Plastoferrite
7. Extrusion profile	Anodized aluminium alloy
8. Guiding element BS screw	Aluminium alloy
9. End stroke seals	NBR
10. Bearing	Steel
11. Rear endcap	Anodized aluminium alloy
12. BS ball screw	Steel

ACCESSORIES FOR SERIES 6E CYLINDERS

ELECTRIC ACTUATION

2

Piston rod socket joint Mod. GY



Piston rod lock nut Mod. U



Clevis pin Mod. S



Rear trunnion ball-joint Mod. R

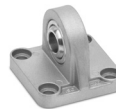

Coupling piece Mod. GKF



Swivel ball joint Mod. GA



90° male trunnion Mod. ZC

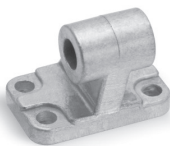

Swivel Combination Mod. C+L+S

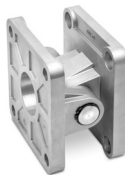

Front flange Mod. D-E

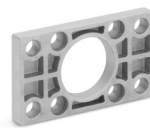

Self aligning rod Mod. GK



Foot mount Mod. B



Rear female trunnion Mod. C and C-H



Rod fork end Mod. G



Rear trunnion male Mod. L



Side clamping bracket Mod. BG



Housing for axial connection Mod. CM

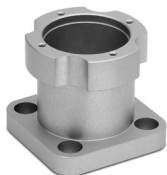

Flange for axial connection Mod. FM

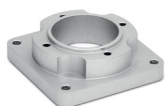

Kit for axial connection Mod. AM



Kit for parallel connection Mod. PM



Kit for axial connection Mod. AR

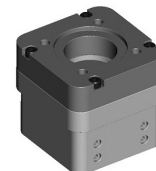

Cylinder bracket Mod. BA

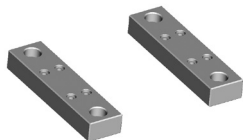

Front spot faced trunnion Mod. FN



Counter bracket for trunnion Mod. BF



Guides Mod. 45NHT



Nuts for slots



All accessories are supplied separately, except for piston rod lock nut Mod. U

HOW TO CALCULATE THE LIFE OF THE CYLINDER

To perform a correct dimensioning of the Series 6E cylinder, you need to consider some facts.

Among these, the most important are:

- Dynamics of the system
- Operation and pause cyclicality
- Work environment
- General performance requirements: repeatability, accuracy, precision, etc.

CALCULATE THE LIFE IN ROTATIONS where:

L_r = Life of the cylinder in number of rotations of the BS ball screw

C = Dynamic load coefficient of the cylinder [N]

F_m = Average axial force applied [N]

f_w = Safety coefficient according to the working conditions

$$L_r = \left(\frac{C}{F_m \cdot f_w} \right)^3 \cdot 10^6$$

CALCULATION OF LIFE IN km where:

L_{km} = Life of the cylinder in km [km]

p = pitch of the BS ball screw [mm]

$$L_{km} = \frac{L_r \cdot p}{10^6}$$

CALCULATION OF THE LIFE IN HOURS where:

L_h = Life of the cylinder in hours

n_m = average number of revolutions of the RDS ball screw [rpm]

$$L_h = \frac{L_r}{n_m \cdot 60}$$

APPLICATION	ACCELERATION [m/s ²]	SPEED [m/s]	DUTY CYCLE	f_w COEFFICIENT
light	< 5,0	< 0,5	< 35%	1,0 ÷ 1,25
normal	5,0 ÷ 15,0	0,5 ÷ 1,0	35% ÷ 65%	1,25 ÷ 1,5
heavy	> 15,0	> 1,0	> 65%	1,5 ÷ 3,0

ANALYSIS OF THE DUTY CYCLE AND OF SYSTEM PAUSES

The analysis of the duty cycle and of the pauses of the system is essential to calculate the average F_m axial loads and the number of average revolutions n_m that act on the cylinder.

Normally, the duty cycle is composed by phases and for each single phase, we can have an acceleration, constant speed or deceleration.

F_m = CALCULATION OF THE AVERAGE AXIAL FORCE

n_m = CALCULATION OF THE AVERAGE NUMBER OF REVOLUTIONS

$$F_m = \sqrt[3]{\frac{(F_{a1}^3 \cdot n_{a1} \cdot t_{a1}) + (F_{vc1}^3 \cdot n_{vc1} \cdot t_{vc1}) + (F_{d1}^3 \cdot n_{d1} \cdot t_{d1}) + \dots + (F_{an}^3 \cdot n_{an} \cdot t_{an}) + (F_{vcn}^3 \cdot n_{vcn} \cdot t_{vcn}) + (F_{dnn}^3 \cdot n_{dnn} \cdot t_{dnn})}{(n_{a1} \cdot t_{a1}) + (n_{vc1} \cdot t_{vc1}) + (n_{d1} \cdot t_{d1}) + \dots + (n_{an} \cdot t_{an}) + (n_{vcn} \cdot t_{vcn}) + (n_{dnn} \cdot t_{dnn})}}$$

$$n_m = \left\{ \frac{(n_{a1} \cdot t_{a1}) + (n_{vc1} \cdot t_{vc1}) + (n_{d1} \cdot t_{d1}) + \dots + (n_{an} \cdot t_{an}) + (n_{vcn} \cdot t_{vcn}) + (n_{dnn} \cdot t_{dnn})}{t_{a1} + t_{vc1} + t_{d1} + \dots + t_{an} + t_{vcn} + t_{dnn}} \right\}$$

The table shown below reports the values of acceleration, speed and deceleration for each phase.

		F [N]	n [rpm]	Time %
PHASE 1	Acceleration	Fa1	na1	ta1
	Constant speed	Fvc1	nvc1	tvc1
	Deceleration	Fd1	nd1	td1
PHASE 2	Acceleration	Fa2	na2	ta2
	Constant speed	Fvc2	nvc2	tvc2
	Deceleration	Fd2	nd2	td2
PHASE "n -1"	Acceleration	Fan-1	nan-1	tan-1
	Constant speed	Fvcn-1	nvcn-1	tvcn-1
	Deceleration	Fdn-1	ndn-1	tdn-1
PHASE "n"	Acceleration	Fan	nan-1	tan-1
	Constant speed	Fvcn	nvcn-1	tvcn-1
	Deceleration	Fdn	ndn-1	tdn-1
TOTAL				100%

APPLICATION EXAMPLE

phase 1	$F_{a1} = 142 \text{ N};$ $n_{a1} = 630 \text{ rpm};$ $t_{a1} = 0,7 \text{ %};$	$F_{vc1} = 98 \text{ N};$ $n_{vc1} = 1260 \text{ rpm};$ $t_{vc1} = 12,9 \text{ %};$	$F_{d1} = 54 \text{ N};$ $n_{d1} = 630 \text{ rpm};$ $t_{d1} = 0,7 \text{ %};$
phase 2	$F_{a2} = 616 \text{ N};$ $n_{a2} = 450 \text{ rpm};$ $t_{a2} = 4,8 \text{ %};$	$F_{vc2} = 589 \text{ N};$ $n_{vc2} = 900 \text{ rpm};$ $t_{vc2} = 33,3 \text{ %};$	$F_{d2} = 562 \text{ N};$ $n_{d2} = 450 \text{ rpm};$ $t_{d2} = 4,8 \text{ %};$
phase 3	$F_{a3} = 997 \text{ N};$ $n_{a3} = 240 \text{ rpm};$ $t_{a3} = 7,1 \text{ %};$	$F_{vc3} = 981 \text{ N};$ $n_{vc3} = 480 \text{ rpm};$ $t_{vc3} = 28,6 \text{ %};$	$F_{d3} = 965 \text{ N};$ $n_{d3} = 240 \text{ rpm};$ $t_{d3} = 7,1 \text{ %};$

in this way it is possible to determine:

$$K_1 = (F_{a1}^3 \cdot n_{a1} \cdot t_{a1}) + (F_{vc1}^3 \cdot n_{vc1} \cdot t_{vc1}) + (F_{d1}^3 \cdot n_{d1} \cdot t_{d1}) \quad n_1 = (n_{a1} \cdot t_{a1}) + (n_{vc1} \cdot t_{vc1}) + (n_{d1} \cdot t_{d1}) \quad T_1 = t_{a1} + t_{vc1} + t_{d1}$$

$$K_2 = (F_{a2}^3 \cdot n_{a2} \cdot t_{a2}) + (F_{vc2}^3 \cdot n_{vc2} \cdot t_{vc2}) + (F_{d2}^3 \cdot n_{d2} \cdot t_{d2}) \quad n_2 = (n_{a2} \cdot t_{a2}) + (n_{vc2} \cdot t_{vc2}) + (n_{d2} \cdot t_{d2}) \quad T_2 = t_{a2} + t_{vc2} + t_{d2}$$

$$K_3 = (F_{a3}^3 \cdot n_{a3} \cdot t_{a3}) + (F_{vc3}^3 \cdot n_{vc3} \cdot t_{vc3}) + (F_{d3}^3 \cdot n_{d3} \cdot t_{d3}) \quad n_3 = (n_{a3} \cdot t_{a3}) + (n_{vc3} \cdot t_{vc3}) + (n_{d3} \cdot t_{d3}) \quad T_3 = t_{a3} + t_{vc3} + t_{d3}$$

concluding, we know that:

$$F_m = \sqrt[3]{\frac{(K_1 + K_2 + K_3)}{(n_1 + n_2 + n_3)}} = 596,64 \text{ N}$$

$$n_m = \frac{n_1 + n_2 + n_3}{T_1 + T_2 + T_3} = 685,7 \text{ rpm}$$

		F [N]	n [rpm]	Time %
PHASE 1	Acceleration	142	630	0,7
	Constant speed	98	1260	12,9
	Deceleration	54	630	0,7
PHASE 2	Acceleration	616	450	4,8
	Constant speed	589	900	33,3
	Deceleration	562	450	4,8
PHASE 3	Acceleration	997	240	7,1
	Constant speed	981	480	28,6
	Deceleration	965	240	7,1
TOTAL				100,0

HOW TO CALCULATE THE DRIVING TORQUE [Nm]

F_A = Total force acting from outside [N]

p = Pitch of the ball screw [mm]

η = Performance

C_{M1} = Driving torque due to external agents [Nm]

$$C_{TOT} = C_{M1} + C_{M2} + C_{M3}$$

$$F_A = F_E + \mu \cdot m_E \cdot g$$

$$C_{M1} = \frac{F_A \cdot p}{2\pi \cdot 1000} \cdot \frac{1}{\mu}$$

J_{TOT} = Moment of inertia of rotating components [kg·m²]

J_F = Moment of inertia of fixed-length rotating components [kg·m²]

J_V = Moment of inertia of variable-length rotating components [kg·m²]

K_V = Coefficient of inertia of variable-length rotating components [kg·mm²/mm]

C = Rod stroke [mm]

$\dot{\omega}$ = Angular acceleration [rad/s²]

a = Linear acceleration of the ball screw [m/s²]

C_{M2} = Driving torque due to rotating components [Nm]

$$J_{TOT} = (J_F + J_V) \cdot 10^{-6}$$

$$J_V = K_V \cdot C$$

$$\dot{\omega} = \frac{a \cdot 2\pi \cdot 1000}{p}$$

$$C_{M2} = J_{TOT} \cdot \dot{\omega} \cdot \frac{1}{\mu}$$

F_{TT} = Force needed to move sliding components [N]

F_{TF} = Force needed to move fixed-length sliding components [N]

F_{TV} = Force needed to move variable-length sliding components [N]

m_{c1} = Mass of the fixed-length sliding components [kg]

K_{TV} = Mass coefficient of variable-length sliding components [kg/mm]

C_{M3} = Driving torque due to sliding components [Nm]

$$F_{TT} = F_{TF} + F_{TV}$$

$$F_{TF} = m_{c1} \cdot a$$

$$F_{TV} = K_{TV} \cdot C \cdot a$$

$$C_{M3} = \frac{F_{TT} \cdot p}{2\pi \cdot 1000} \cdot \frac{1}{\mu}$$

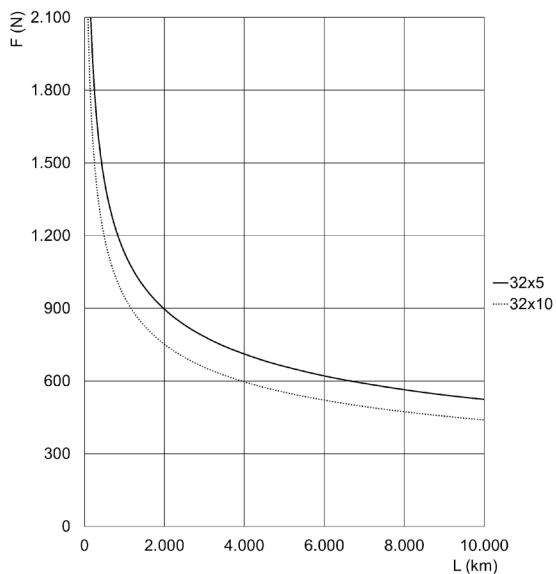
Life of the cylinder according to the average axial force applied (environmental T and standard conditions of use)

Size 32

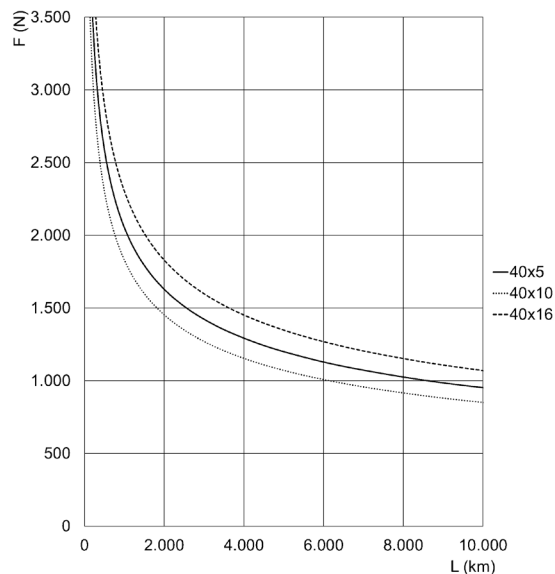
F = Axial Force [N]
 L = life [km]
 Curves calculated with $fw = 1$

Size 40

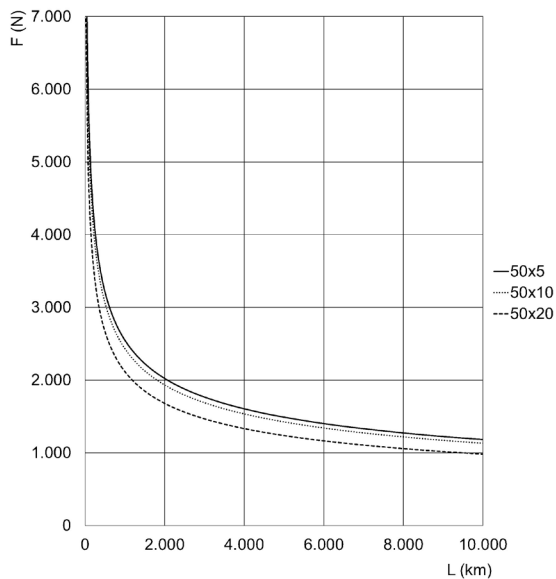
F = Axial Force [N]
 L = life [km]
 Curves calculated with $fw = 1$

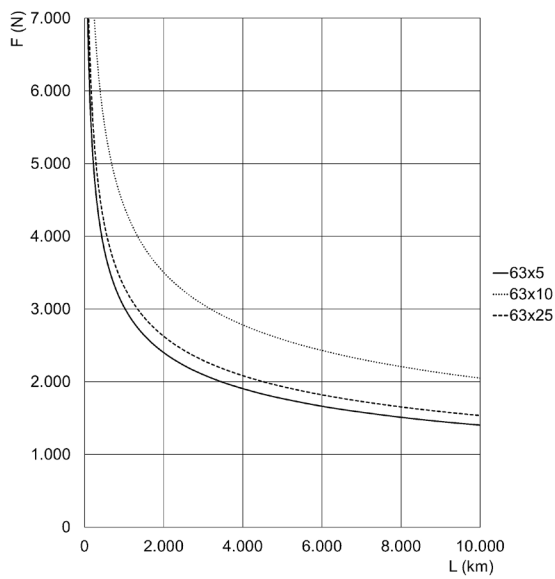

Size 50

F = Axial Force [N]
 L = life [km]
 Curves calculated with $fw = 1$

Size 63

F = Axial Force [N]
 L = life [km]
 Curves calculated with $fw = 1$

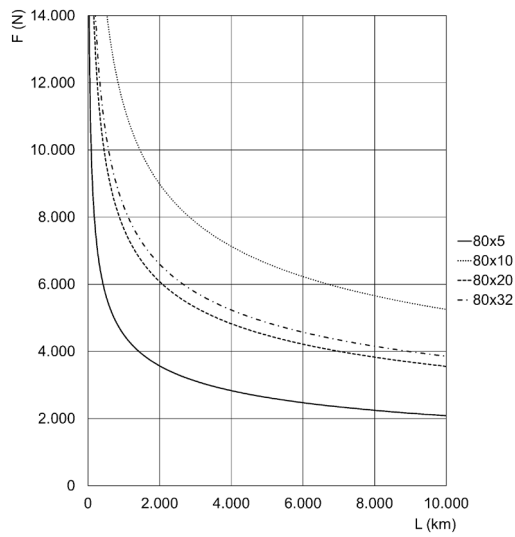
Life of the cylinder according to the average axial force applied (environmental T and standard conditions of use)



Size 80

F = Axial Force [N]
L = life [km]
Curves calculated with $f_w = 1$

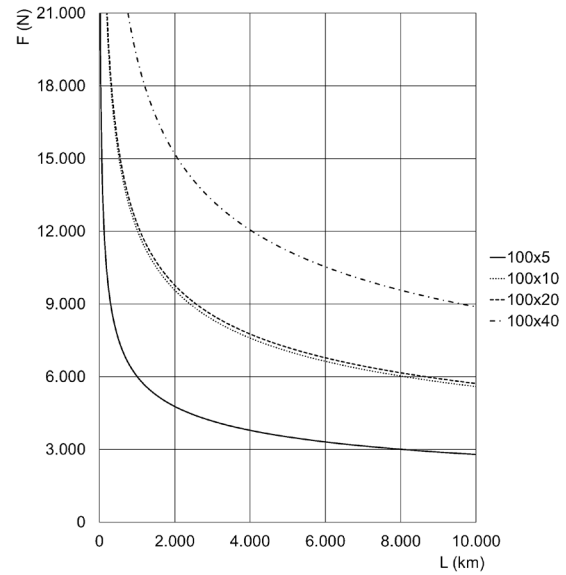

Size 100

F = Axial Force [N]
L = life [km]
Curves calculated with $f_w = 1$

Maximum speed of the cylinder according to its stroke

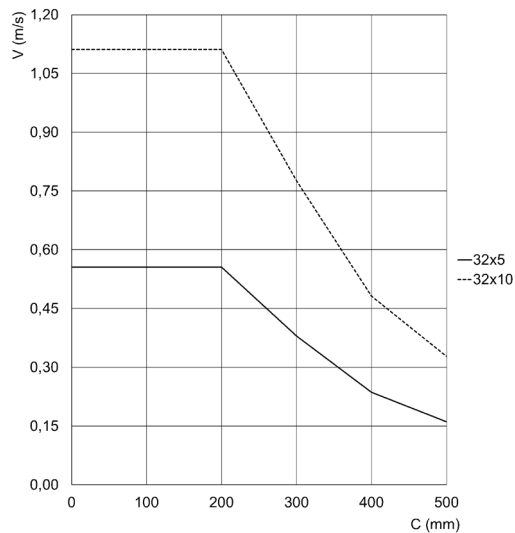

Size 32

V = speed [m/s]
c = stroke [mm]

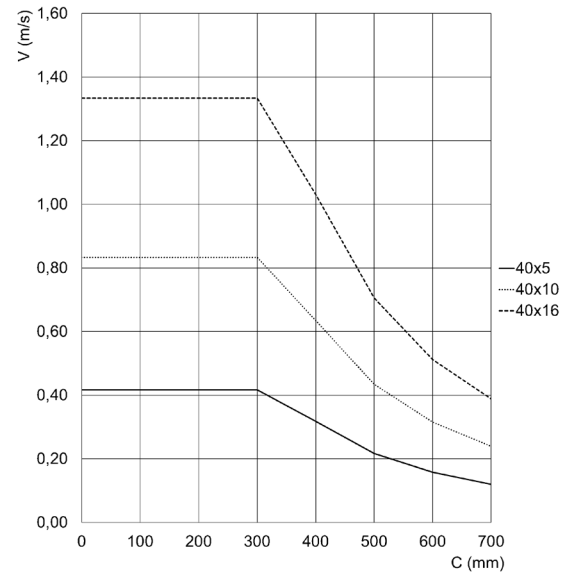

Size 40

V = speed [m/s]
c = stroke [mm]

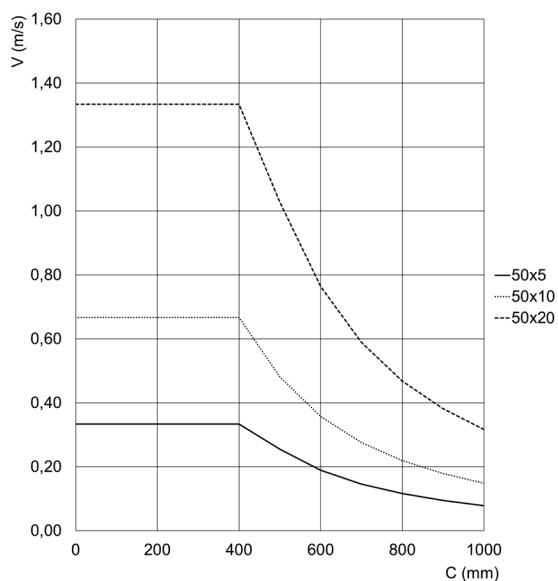
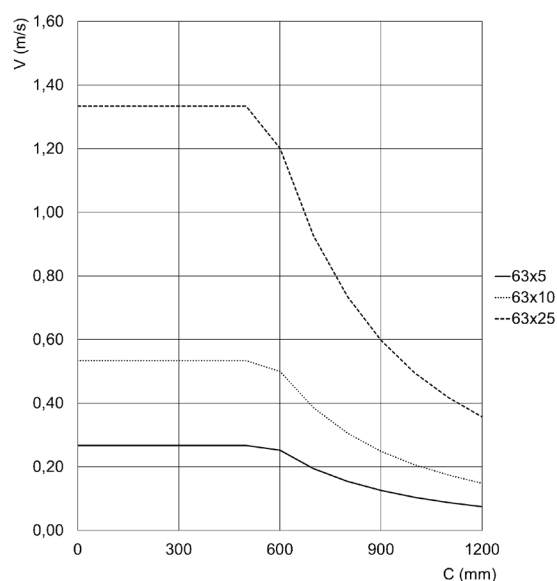
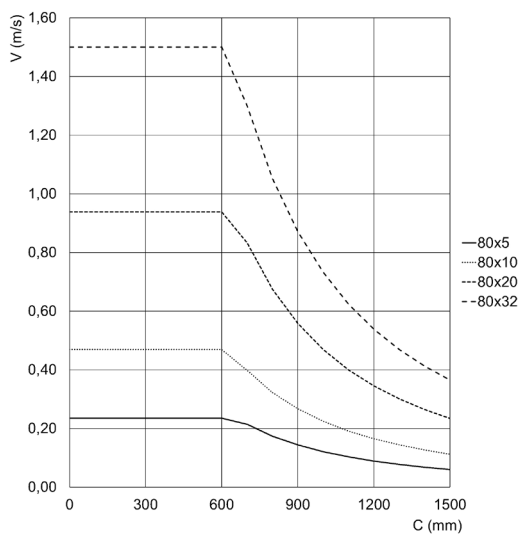
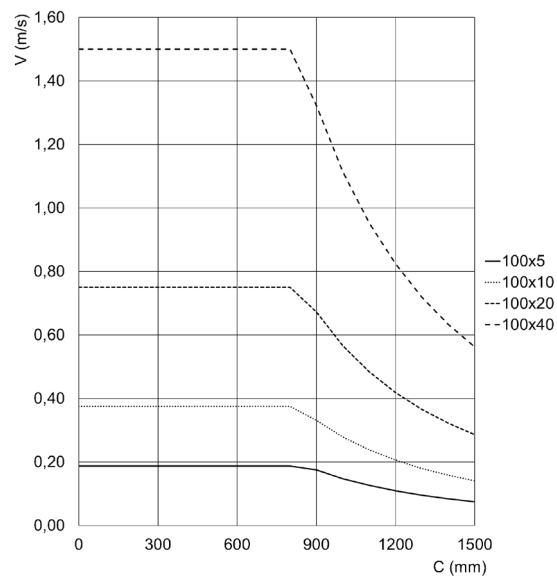
Maximum speed of the cylinder according to its stroke

Size 50
 $V = \text{speed [m/s]}$
 $c = \text{stroke [mm]}$

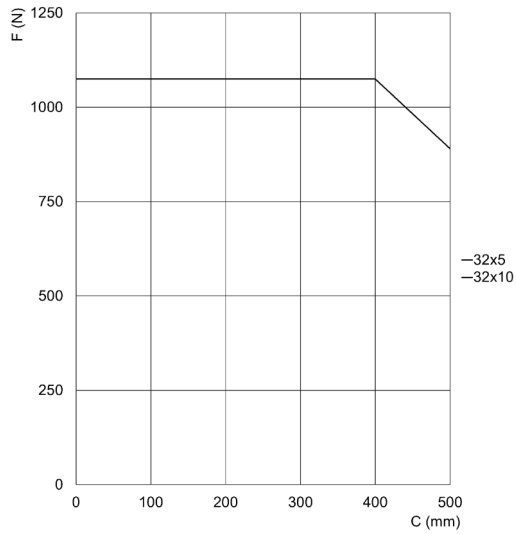
Size 63
 $V = \text{speed [m/s]}$
 $c = \text{stroke [mm]}$

Size 80
 $V = \text{speed [m/s]}$
 $c = \text{stroke [mm]}$

Size 100
 $V = \text{speed [m/s]}$
 $c = \text{stroke [mm]}$

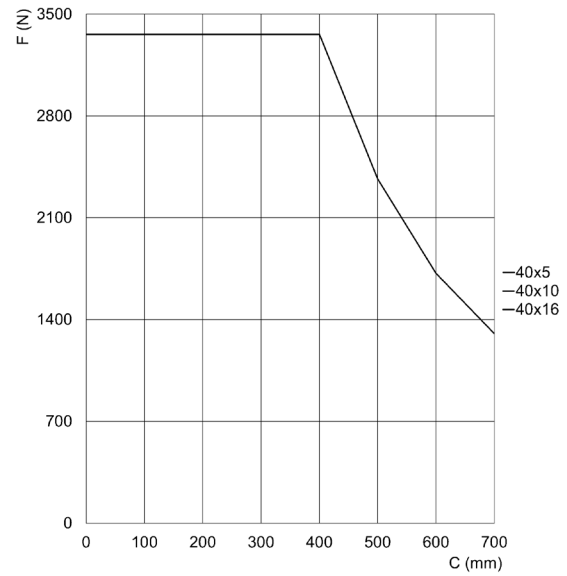
Maximum force of the cylinder according to its stroke



Size 32

F = static axial Force [N]
 c = stroke [mm]



Size 40

F = static axial Force [N]
 c = stroke [mm]

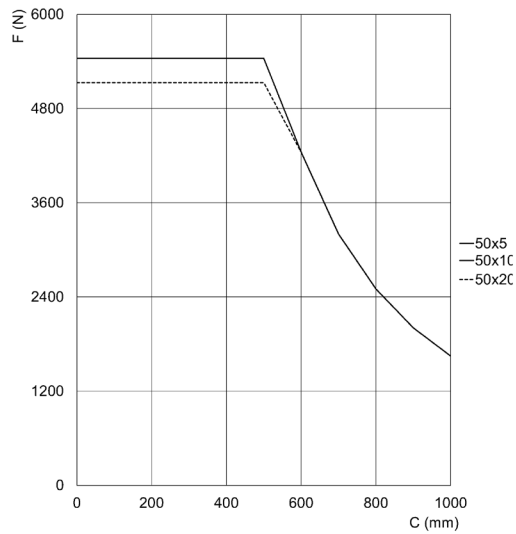

Size 50

F = static axial Force [N]
 c = stroke [mm]

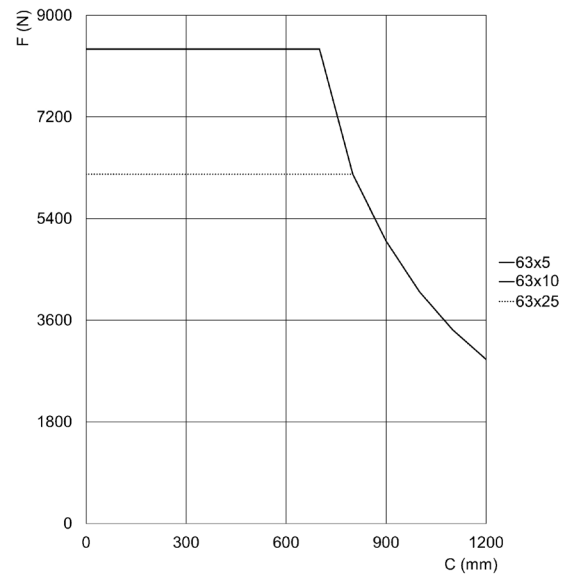

Size 63

F = static axial Force [N]
 c = stroke [mm]

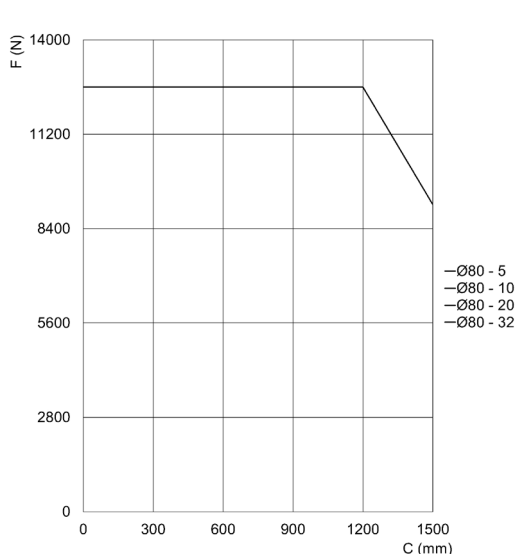
Maximum force of the cylinder according to its stroke

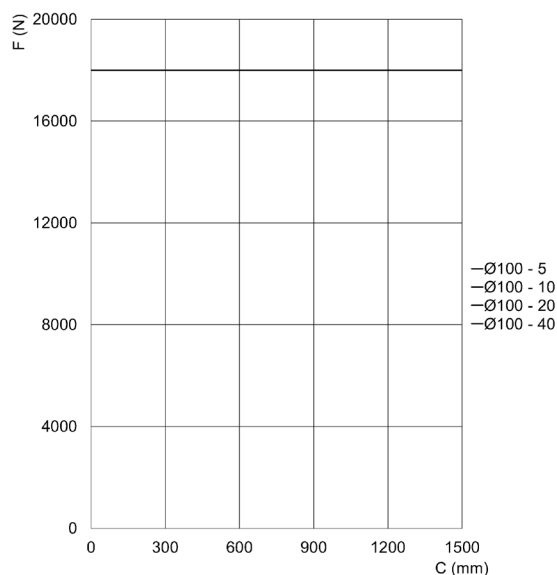
Size 80

 F = static axial Force [N]
 c = stroke [mm]

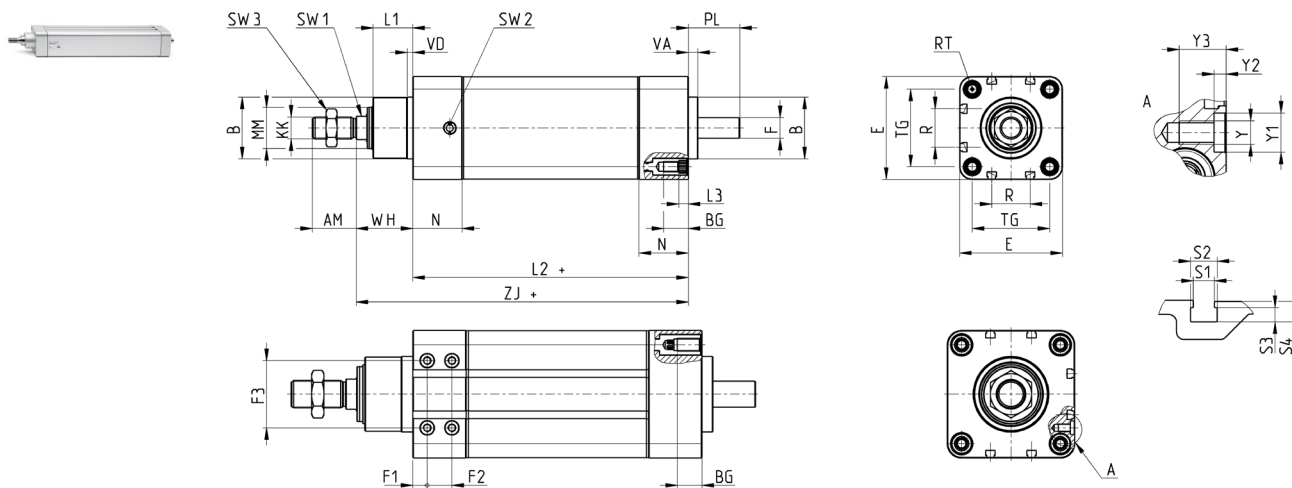
Size 100

 F = static axial Force [N]
 c = stroke [mm]

Series 6E cylinders Series 6E

+ = add the stroke

Size	AM	B	BG	E	F	F1	F2	F3	KK	L1	L2+	L3	MM	N	R	RT	PL	SW1	SW2	SW3	TG	VA	VD	Y	Y1	Y2	Y3	WH	ZI	S1	S2	S3	S4	Weight stroke 0 [g]	Weight stroke [kg/m]
32	22	30	16	46,5	8	-	-	-	M10x1,25	20	125	5,5	18	26	13	M6	21	10	G1/8	17	32,5	6	4	-	-	-	30	155	5,4	6,8	3,65	5	1175	3,77	
40	24	35	16	55,4	10	-	-	-	M12x1,25	22	142	5,5	22	27	13,5	M6	24	13	G1/8	19	38	6	4	-	-	-	33	175	5,4	6,8	3,65	5	1395	5,30	
50	32	40	16	64,9	12	-	-	-	M16x1,5	26	173	5,5	25	36	16	M8	30	17	G1/8	24	46,5	7	4	-	-	-	38	211	5,4	6,8	3,65	5	2280	6,03	
63	32	45	16	75	15	-	-	-	M16x1,5	29	201	5,5	30	36	28	M8	38	17	G1/8	24	56,5	7	4	-	-	-	42	242,5	5,4	6,8	3,65	5	3500	9,77	
80	40	55*	18	93	19	10,5	18	49	M20x1,5	35	211	-	40	39	30	M10	39	22	G1/4	30	72	8	8	M6	10	3	12	49	260	5,4	6,8	3,65	5	6440	13,70
100	40	65*	18	115	24	13	18	62	M20x1,5	38	232	-	50	44	40	M10	42	22	G1/4	30	89	8	8	M8	12	3	16	51	283	5,4	6,8	3,65	5	10725	20,50

* dimension not in compliance with ISO 15552 standard

Housing for axial connection Mod. CM



Material:
anodized aluminium

Supplied with:
1x housing
4x screws

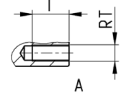
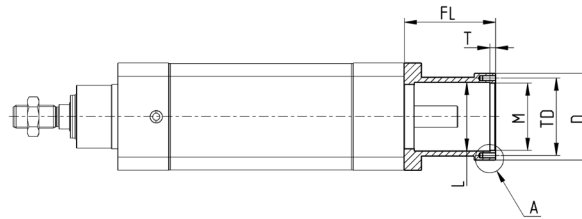
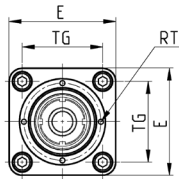

+ = add the stroke

Mod.	Size	XT	E	$\varnothing D$	TG	FL	$\varnothing L$	$\varnothing M^{(h7)}$	T	TD	RT	I	Weight [g]
CM-6E-32	32	201	46,5	42	32,5	46	29	32	4	37	M3	9	100
CM-6E-40	40	224	55,4	52	38	49	36	37	4	43	M3	9	150
CM-6E-50	50	267	64,9	58	46,5	56	39	42	4	49	M4	9	225
CM-6E-63	63	306,5	75	60,5	56,5	64	48	47	4	54	M4	9	280

Flange for axial connection Mod. FM

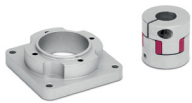

Material:
anodized aluminium

Supplied with:
1x flange
1x flexible coupling
4x screws
4x motor connection screws

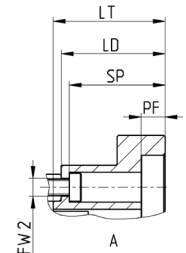
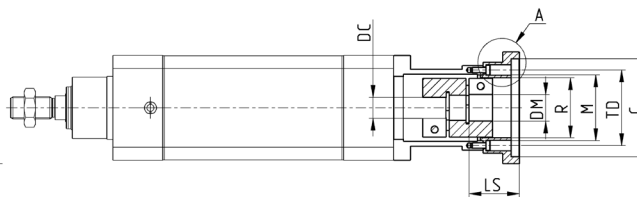
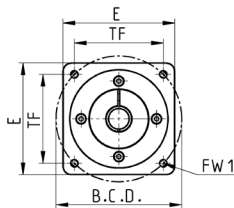

+ = add the stroke

Mod.	Size	Housing	Motor	XR	$\varnothing C^{(h7)}$	PF	LT	LD	$\varnothing M^{(h7)}$	E	$\varnothing R$	TF	$\varnothing B.C.D.$	FW1	$\varnothing TD$	SP	$\varnothing FW2$	$\varnothing DC$	$\varnothing DM$	LS	Nominal torque [Nm] ^(A)	Max. torque [Nm] ^(B)	J (Kgm ²)	Weight [g]	η
FM-6E-32-0100	32	CM-6E-32	MTB-010-...	210	30	6	11	9	32	42	29	-	45	M3	37	6	3,5	8	8	22	9	18	2	65	0,78
FM-6E-32-0023	32	CM-6E-32	MTS-23-...	208	38,1	5	9	7	32	56,4	29	47,1	-	M4	37	5	3,5	8	6,35	25	9	18	2	140	0,78
FM-6E-40-0400	40	CM-6E-40	MTB-040-...	242	50	3,5	20	18	37	60	33	-	70	M5	43	3,5	3,5	10	14	40	12,5	25	3	140	0,78
FM-6E-40-0023	40	CM-6E-40	MTS-23-...	231	38,1	5	9	7	37	56,4	33	47,1	-	M4	43	5	3,5	10	6,35	29,3	12,5	25	3	215	0,78
FM-6E-50-0400	50	CM-6E-50	MTB-040-...	284	50	6	19	17	42	60	37	-	70	M5	49	14	4,5	12	14	37,3	12,5	25	3	210	0,78
FM-6E-50-0024	50	CM-6E-50	MTS-24-...	274	38,1	3	9	7	42	58	37	47,1	-	M4	49	4	4,5	12	8	29,3	12,5	25	3	190	0,78
FM-6E-63-0750	63	CM-6E-63	MTB-075-...	332,5	70	6	28	26	47	80	43	-	90	M6	54	24	4,5	15	19	54,8	17	34	10	565	0,78
FM-6E-63-0024	63	CM-6E-63	MTS-24-...	313,5	38,1	5	9	7	47	60,5	43	47,1	-	M4	54	5	4,5	15	8	29,3	12,5	25	3	200	0,78

ELECTROMECHANICAL CYLINDERS
SERIES 6E - ACCESSORIES
Kit for axial connection Mod. AM

ELECTRIC ACTUATION

2

- Supplied with:**
- 1x housing
 - 1x flange
 - 1x flexible coupling
 - 4x screws to connect on the cylinder's side
 - 4x screws to connect on the motor's side
 - 3x seals
 - 4x seal washers
 - 4x motor connection screws

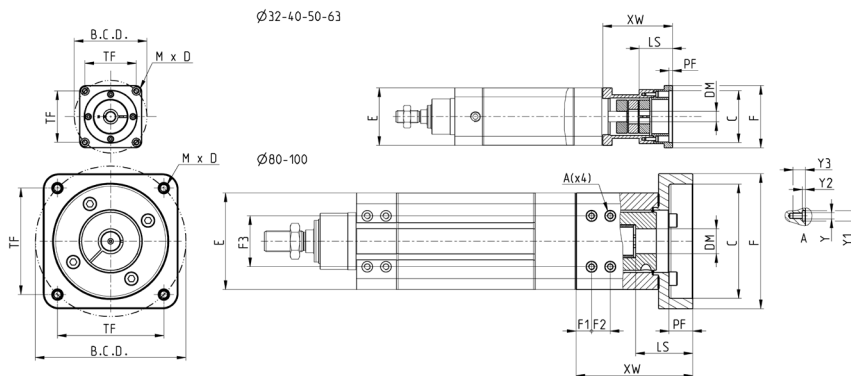

Mod.	Size	Protection class	Motore	ØM	LS	øC	PF	E	F	TF	øB.C.D.	MxD	F1	F2	F3	Y	Y1	Y2	Y3	XW	Nominal torque [Nm] ^(A)	Max. torque [Nm] ^(B)	J (Kgmm ²)	Weight [g]	η
AM-6E-32-0100	32	IP40	MTB-010-...	8	22	30	6	46,5	42	-	45	M3x9	-	-	-	-	-	-	-	55	9	18	2	165	0,78
AM-6E-32-0100P	32	IP65	MTB-010-...	8	22	30	6	46,5	42	-	45	M3x9	-	-	-	-	-	-	-	55	9	18	2	165	0,78
AM-6E-32-0023	32	IP40	MTS-23-...	6,35	25	38,1	5	46,5	56,4	47,1	-	M4x7	-	-	-	-	-	-	-	53	9	18	2	240	0,78
AM-6E-32-0023P	32	IP65	MTS-23-...	6,35	25	38,1	5	46,5	56,4	47,1	-	M4x7	-	-	-	-	-	-	-	53	9	18	2	240	0,78
AM-6E-32-0024P	32	IP65	MTS-24-...	8	21,6	38,1	6	46,5	60	47,1	-	M4x7	-	-	-	-	-	-	-	53,5	9	18	2	240	0,78
AM-6E-40-0400	40	IP40	MTB-040-...	14	40	50	3,5	55,4	60	-	70	M5x8	-	-	-	-	-	-	-	67	12,5	25	3	290	0,78
AM-6E-40-0400P	40	IP65	MTB-040-...	14	40	50	3,5	55,4	60	-	70	M5x8	-	-	-	-	-	-	-	67	12,5	25	3	290	0,78
AM-6E-40-0023	40	IP40	MTS-23-...	6,35	25	38,1	5	55,4	56,4	47,1	-	M4x7	-	-	-	-	-	-	-	56	12,5	25	2	365	0,78
AM-6E-40-0023P	40	IP65	MTS-23-...	6,35	25	38,1	5	55,4	56,4	47,1	-	M4x7	-	-	-	-	-	-	-	56	12,5	25	2	365	0,78
AM-6E-40-0024P	40	IP65	MTS-24-...	8	20,5	38,1	5	55,4	60	47,1	-	M4x8	-	-	-	-	-	-	-	55	12,5	25	3	365	0,78
AM-6E-50-0400	50	IP40	MTB-040-...	14	40	50	6	64,9	60	-	70	M5x9	-	-	-	-	-	-	-	73	12,5	25	3	435	0,78
AM-6E-50-0400P	50	IP65	MTB-040-...	14	40	50	6	64,9	60	-	70	M5x9	-	-	-	-	-	-	-	73	12,5	25	3	435	0,78
AM-6E-50-0750P	50	IP65	MTB-075-...	19	40	70	4,5	64,9	80	-	90	M6x12	-	-	-	-	-	-	-	86	17	34	10	746	0,78
AM-6E-50-0024	50	IP40	MTS-24-...	8	29,3	38,1	3	64,9	58	47,1	-	M4x7	-	-	-	-	-	-	-	63	12,5	25	3	415	0,78
AM-6E-50-0024P	50	IP65	MTS-24-...	8	29,3	38,1	3	64,9	58	47,1	-	M4x7	-	-	-	-	-	-	-	63	12,5	25	3	415	0,78
AM-6E-50-0034P	50	IP65	MTS-34-...	14	37,5	73	4,5	64,9	86	47,1	-	M6x12	-	-	-	-	-	-	-	83	17	34	10	785	0,78
AM-6E-63-0750	63	IP40	MTB-075-...	19	54,8	70	6	75	80	-	90	M6x12	-	-	-	-	-	-	-	90	17	34	10	845	0,78
AM-6E-63-0750P	63	IP65	MTB-075-...	19	54,8	70	6	75	80	-	90	M4x7	-	-	-	-	-	-	-	90	17	34	10	845	0,78
AM-6E-63-0024	63	IP40	MTS-24-...	8	29,3	38,1	5	75	60,5	47,1	-	M6x12	-	-	-	-	-	-	-	71	12,5	25	3	480	0,78
AM-6E-63-0024P	63	IP65	MTS-24-...	8	29,3	38,1	5	75	60,5	47,1	-	M8x14	-	-	-	-	-	-	-	71	12,5	25	3	480	0,78
AM-6E-63-0034P	63	IP65	MTS-34-...	14	36,5	73	3,5	75	86	69,6	-	M6x15	-	-	-	-	-	-	-	88	17	34	10	1025	0,78
AM-6E-80-1000P	80	IP65	MTB-100-...	24	55,7	110	23	93	130	-	90	M8x14	15	18	49	M6	10	3,1	12	112,5	60	120	40	2510	0,78
AM-6E-80-0034P	80	IP65	MTS-34-...	14	37,5	73	5	93	93	69,6	-	M6x15	15	18	49	M6	10	3,1	12	94,5	60	120	40	1885	0,78
AM-6E-100-1000P	100	IP65	MTB-100-...	24	55	110	23	115	130	-	145	M8x14	15	18	62	M8	12	3,1	18	115,5	60	120	40	3465	0,78
AM-6E-100-0034P	100	IP65	MTS-34-...	14	37,5	73	5	115	93	69,6	-	M6x15	15	18	62	M8	12	3,1	18	97,5	60	120	40	2840	0,78

^(A)Continuously applicable torque, under ideal mounting and operating conditions. For further details, please contact service@camozzi.com

^(B)Torque applicable for short intervals, under ideal mounting and operating conditions. For further details, please contact service@camozzi.com

Kit for axial connection Mod. AR

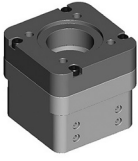

Supplied with:
 2x flanges (1 for size 80)
 8x screws
 1x coupling
 2x seals (1 for size 80)

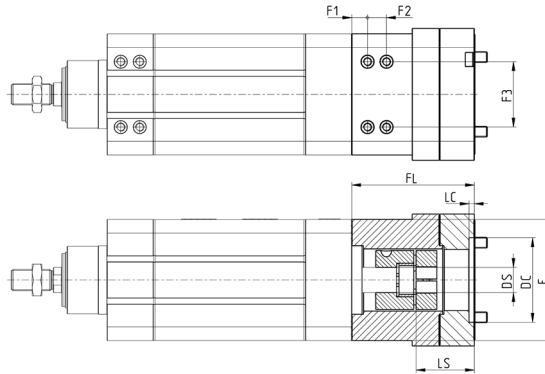
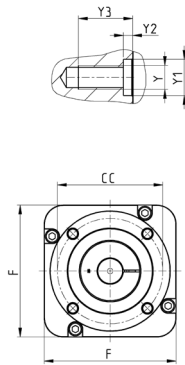

Mod.	Size	Protection class	Gearbox	XE+	FL	F	E	DC	LC	CC	F1	F2	F3	Y	Y1	Y2	Y3	DS	LS	Nominal torque [Nm] ^(A)	Max. torque [Nm] ^(B)	J (Kgmm ²)	Weight [g]	η	
AR-6E-50-R060P	50	IP65	GB-060		288,2	77,2	-	64,9	40	3	-	-	-	-	-	-	-	14	35	16	32	3	630	0,78	
AR-6E-63-R060P	63	IP65	GB-060		339,3	88,6	-	75	40	4	-	-	-	-	-	-	-	14	35	21	42	10	1100	0,78	
AR-6E-80-R080P	80	IP65	GB-080		358	98	-	93	60	5	15	18	49	6	10	3,1	12	20	40	60	120	40	2090	0,78	
AR-6E-100-R120P	100	IP65	GB-120		399,8	116,8	125	115	80	5	100	15	18	62	8	12	3,1	18	25	55	60	120	40	3800	0,78

^(A) Continuously applicable torque, under ideal mounting and operating conditions. For further details, please contact service@camozzi.com

^(B) Torque applicable for short intervals, under ideal mounting and operating conditions. For further details, please contact service@camozzi.com

Kit for parallel connection Mod. PM

The kit includes:

- 1x front cover
- 1x rear cover
- 2x pulleys
- 2x locking sets
- 1x toothed belt 1x belt traction unit
- 4x screws for cylinder's side
- 4x cover rear screws + seal washers
- 6x cover fixing screws
- 3x seals
- 1x seal plug
- 4x motor seal washers
- 4x motor connection screws

ELECTRIC ACTUATION

2

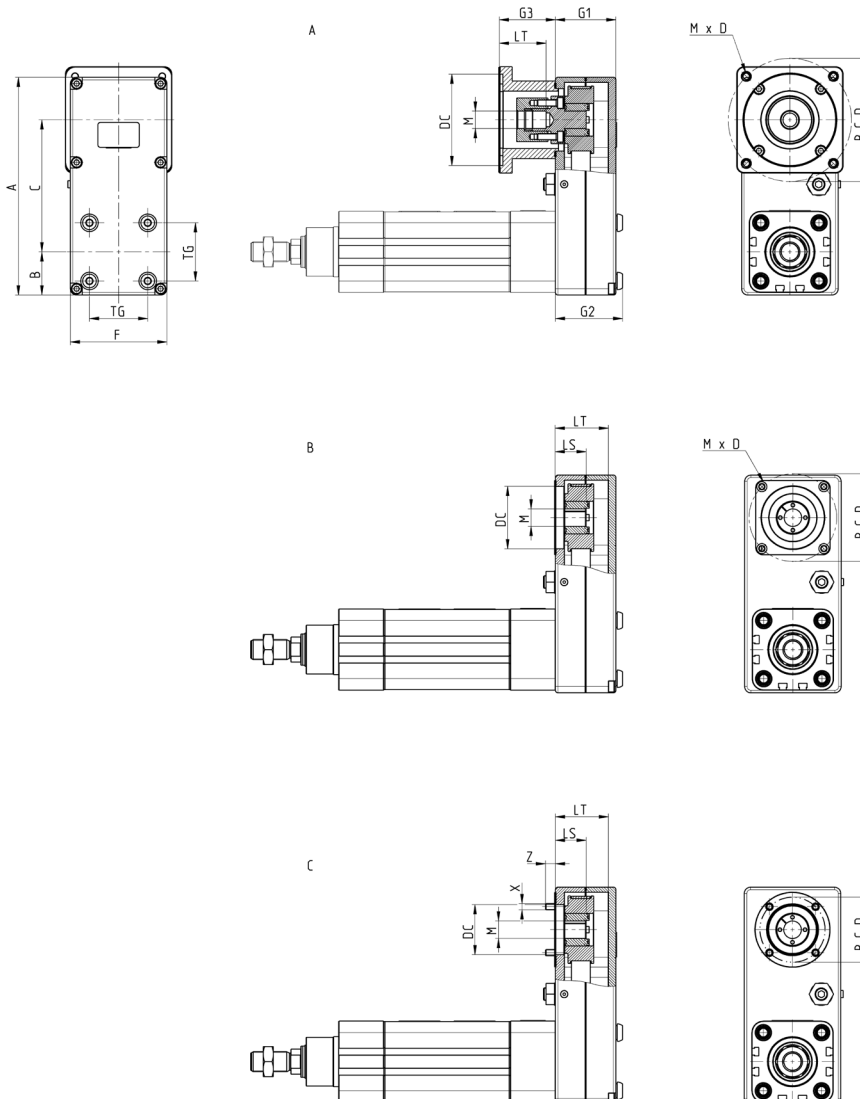

Mod.	Size	Gearbox	Motor	G3*	A	F	G1	G2	B	C	TG	gM	LS	LT	gDC	gBCD	MxD	X	Z	J (kgmm ²)	Weight [g]	η
PM-6E-32-0100P	32	-	MTB-010-...	-	122	54	35	39,2	26,5	65	32,5	8	18,5	29,5	30	45	M3x6	-	-	20,67	450	0,62
PM-6E-32-0024P	32	-	MTS-24-...	30	122	54	35	39,2	26,5	65	32,5	8	-	20,5	38,1	66,6	M4x10	-	-	27,78	450	0,62
PM-6E-40-0400P	40	-	MTB-040-...	-	154	67	46	50,2	30	90	38	14	25	40,6	50	70	M5x7	-	-	133,8	960	0,62
PM-6E-40-0024P	40	-	MTS-24-...	-	154	67	46	50,2	30	90	38	8	20,5	40,5	38,1	66,6	M4x7	-	-	90,3	960	0,62
PM-6E-50-0400P	50	-	MTB-040-...	-	174	77	48	53,4	34,5	105,5	46,5	14	24,5	42,5	50	70	M5x7	-	-	229,6	1375	0,62
PM-6E-50-0034P	50	-	MTS-34-...	44,5	174	77	48	53,4	34,5	105,5	46,5	14	-	47	73,025	98,42	M6x10	-	-	276,3	1375	0,62
PM-6E-50-R060P	50	GB-060-...	MTB-040-...	-	174	77	48	53,4	34,5	105,5	46,5	14	24,5	42,5	40	52	-	M5	8	229,6	1375	0,62
PM-6E-63-0750P	63	-	MTB-075-...	-	192	87	50	55,4	41	107	56,5	19	29,5	43,5	70	90	M6x8	-	-	357,1	1675	0,62
PM-6E-63-0034P	63	-	MTS-34-...	-	192	87	50	55,4	41	107	56,5	14	27,5	43,5	73,025	98,42	M6x8	-	-	244,5	1675	0,62
PM-6E-63-R060P	63	GB-060-...	MTB-040-...	-	192	87	50	55,4	41	107	56,5	14	27,5	43,5	40	52	-	M5	7,5	434,8	1675	0,62
PM-6E-80-1000P	80	-	MTB-100-...	-	310	135	70	77	65	180	72	24	41	60,5	110	145	M8x10	-	-	1053,1	4457	0,62
PM-6E-80-0034P	80	-	MTS-34-...	-	310	135	70	77	65	180	72	14	35	60,5	73,025	98,42	M6x10	-	-	970	4457	0,62
PM-6E-80-R080P	80	GB-080-...	MTB-075-...	-	310	135	70	77	65	180	72	19	36	60,5	60	70	-	M6	9,5	999,6	4457	0,62
PM-6E-100-1000P	100	-	MTB-100-...	-	310	135	70	77	65	180	72	24	41	60,5	110	145	M8x10	-	-	1110,8	4457	0,62
PM-6E-100-0034P	100	-	MTS-34-...	-	310	135	70	77	65	180	72	14	35	60,5	73,025	98,42	M6x10	-	-	1031,2	4457	0,62
PM-6E-100-R080P	100	GB-080-...	MTB-075-...	-	310	135	70	77	65	180	72	19	36	60,5	60	70	-	M6	9,5	1054,8	4457	0,62

TRANSMISSIBLE POWER KIT PM

The curves refer to a duty cycle of 70%

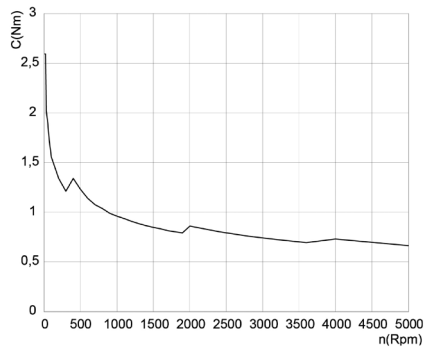

PM-6E 32...
C = Torque [Nm]
n = number of revolutions per minute [Rpm]

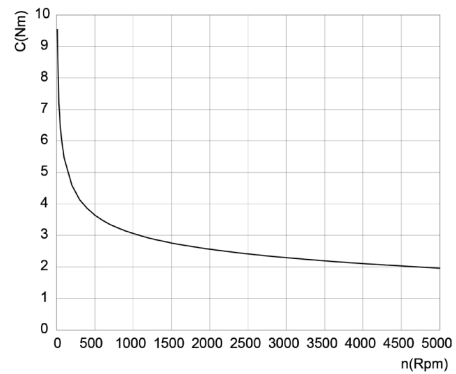

PM-6E 40...
C = Torque [Nm]
n = number of revolutions per minute [Rpm]

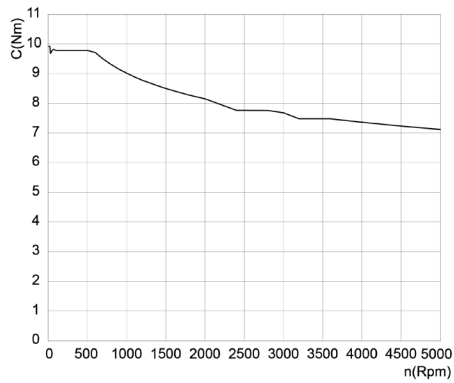

PM-6E 50...
C = Torque [Nm]
n = number of revolutions per minute [Rpm]

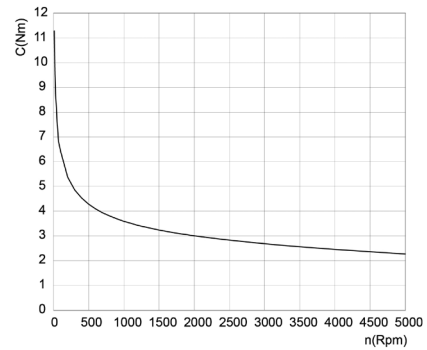

PM-6E 63...
C = Torque [Nm]
n = number of revolutions per minute [Rpm]

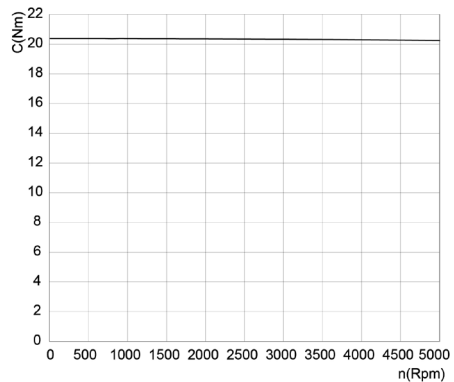

PM-6E 80...
C = Torque [Nm]
n = number of revolutions per minute [Rpm]

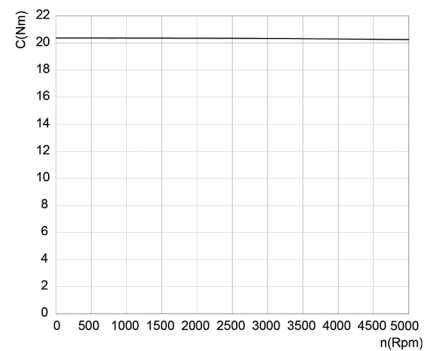

PM-6E 100...
C = Coppia [Nm]
n = numero di giri al minuto [Rpm]

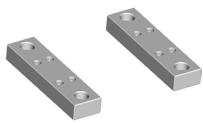
Cylinder bracket Mod. BA-6E

Supplied with:
 2x feet
 8x centering rings
 8x screws

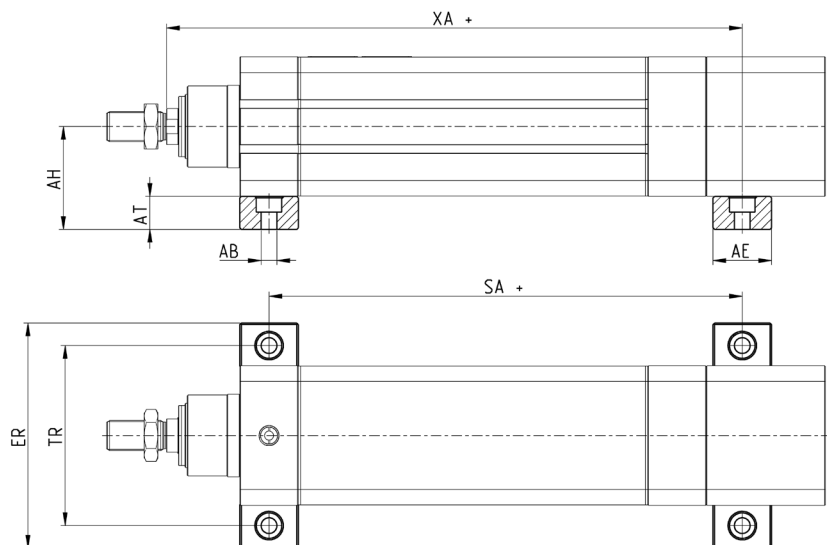

Mod.	Size	XA	AH	AT	AB	SA +	ER	TR	AE	Weight [g]
BA-6E-80	80	283,85	68,5	22	10,5	215,5	150	120	39	630
BA-6E-100	100	306,85	79,5	22	10,5	234	170	140	44	800

Foot bracket Mod. B-6E

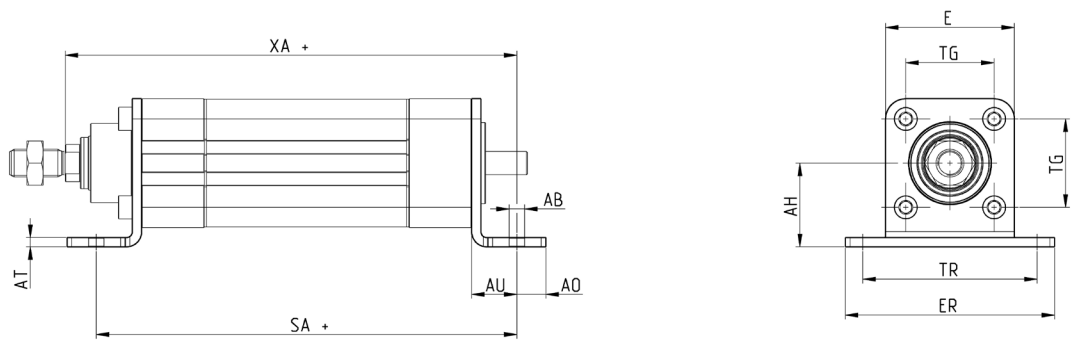

Material:
zinc-plated steel

Supplied with:
2x feet
8x screws

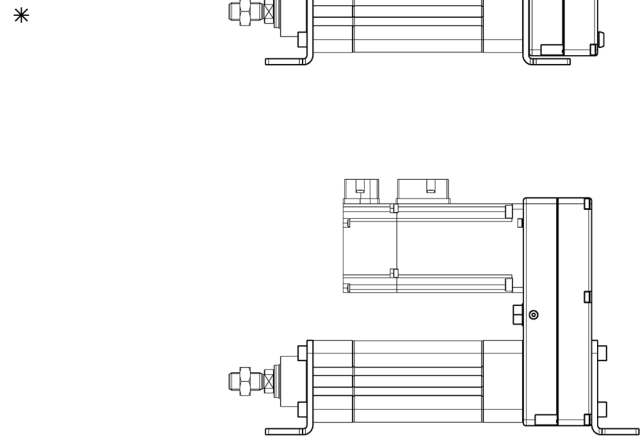
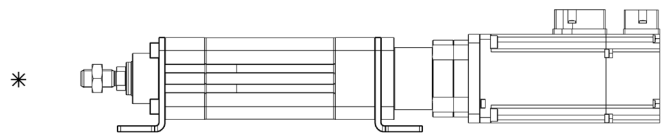

ELECTRIC ACTUATION

2



* Mounting available for sizes 32, 40, 50 and 63 only
+ = add the stroke

Mod.	Size	SA +	XA	AH	TG	TR	AT	AU	AO	AB	ER	E	Weight [g]
B-6E-32	32	164	174,5	32	32,5	65	4	19,5	12,5	6,6	79	46,5	275
B-6E-40	40	181	194,5	36	38	75	4	19,5	12,5	6,6	90	55,4	340
B-6E-50	50	223	236	45	46,5	90	5	25	15	9	110	64,9	635
B-6E-63	63	251	267,5	50	56,5	100	5	25	15	9	120	75	755
B-6E-80	80	278	293,5	68,5	72	120	6	33,5	17,5	10,5	140	93	1300
B-6E-100	100	299	316,5	79,5	89	140	6	33,5	17,5	10,5	170	115	1800

Front spot faced trunnion Mod. FN

Material:
zinc-plated steel

Supplied with:
1x spot faced trunnion
4x screws

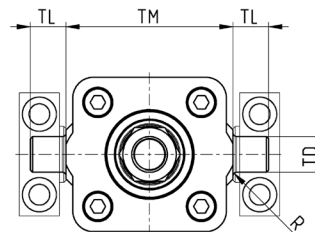
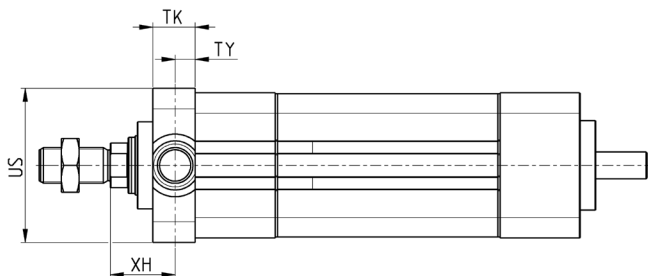

Mod.	∅	TK	TY	XH	US	TL	TM	TD	R
FN-32	32	14	6,5	23,5	46	12	50	12	1
FN-40	40	19	9	24	59	16	63	16	1,5
FN-50	50	19	9	29	69	16	75	16	1,6
FN-63	63	24	11,5	30,5	84	20	90	20	1,6
FN-6E-80	80	24	11,5	34,5	102	20	110	20	1,6
FN-6E-100	100	29	14	37	125	25	132	25	2

Counter bracket for front trunnion Mod. BF

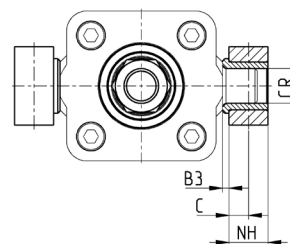
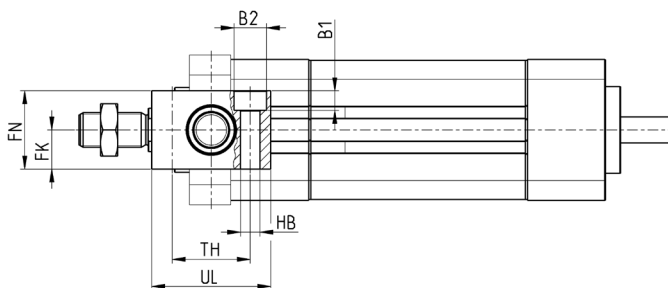

Material:
aluminium

Supplied with:
2x supports

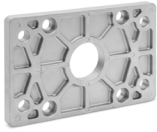

Mod.	∅	∅ _{CR}	NH	C	B3	TH	UL	FK	FN	B1	∅ _{B2}	∅ _{HB}
BF-32	32	12	15	7,5	3	32	46	15	30	6,8	11	6,6
BF-40-50	40 - 50	16	18	9	3	36	55	18	36	9	15	9
BF-63-80	63 - 80	20	20	10	3	42	65	20	40	11	18	11
BF-100-125	100 - 125	25	25	12,5	3,5	50	75	25	50	13	20	14

Front flange Mod. D-E



Material:
aluminium for $\varnothing 32 \div \varnothing 100$

Supplied with:
1x flange
4x screws

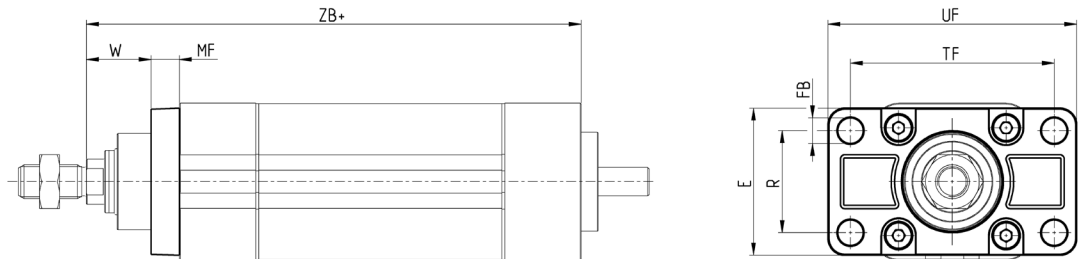

+ = add the stroke

Mod.	Size	W	MF	ZB +	TF	R	UF	E	\varnothing_{FB}
D-E-41-32	32	20	10	155	64	32	80	45	7
D-E-41-40	40	23	10	175	72	36	90	52	9
D-E-41-50	50	26,5	12	211	90	43	110	65	9
D-E-41-63	63	30	12	242,5	100	50	120	75	9
D-E-6E-80	80	30	16	260	126	63	150	95	12
D-E-6E-100	100	35	16	283	150	75	170	115	14

Side clamping bracket Mod. BG



Material:
aluminium

Supplied with:
2x clamps

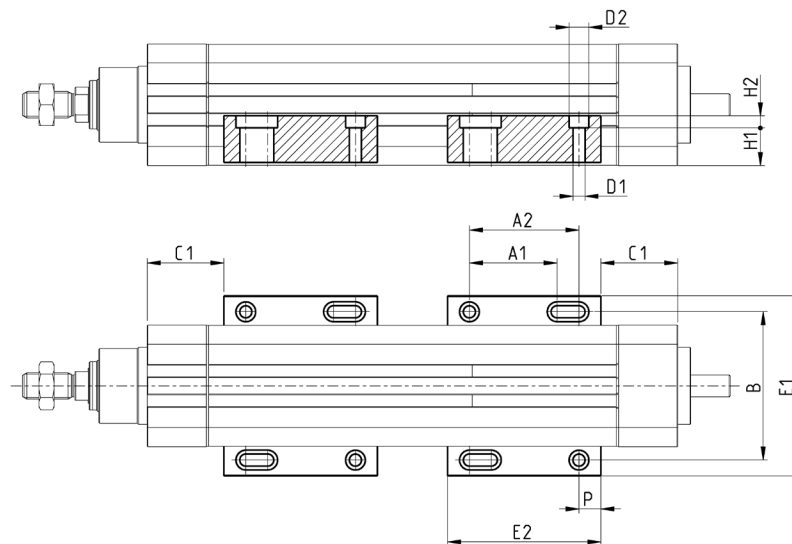

Mod.	Size	C1	E1	E2	P	A1	A2	B	Screw	\varnothing_{D1}	\varnothing_{D2}	H1	H2	Weight [g]
BG-6E-32	32	35	71	70	10	40	50	58,5	M4	4,5	7,5	13,5	4,5	80
BG-6E-40	40	35	82	70	10	40	50	67,5	M5	5,5	9	16,9	5,5	105
BG-6E-50	50	35	93	70	10	40	50	76,5	M6	6,5	10,5	19,4	6,5	125
BG-6E-63	63	35	103,5	70	10	40	50	87	M6	6,5	10,5	18,9	6,5	125
BG-6E-80	80	45	131	90	17,5	50	60	111,6	M8	8,5	14	22,5	8,5	260
BG-6E-100	100	50	153	90	17,5	50	60	133,6	M8	8,5	14	28	8,5	300

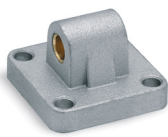
ELECTROMECHANICAL CYLINDERS
SERIES 6E - ACCESSORIES
Rear male trunnion Mod. L

Material:
aluminium

Supplied with:
1x male trunnion
4x screws

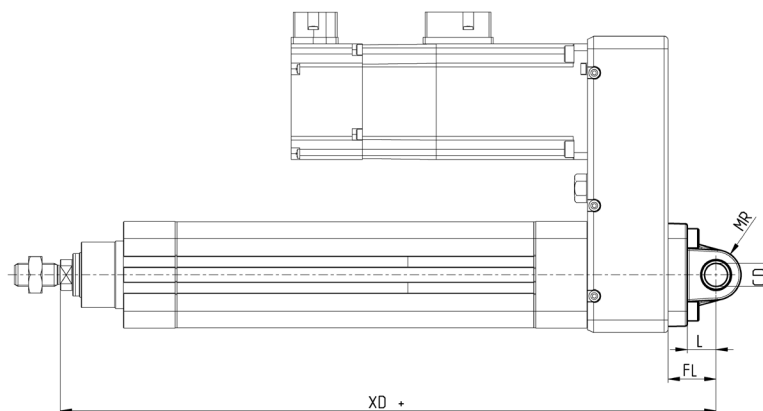
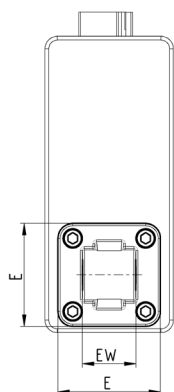

+ = add the stroke

Mod.	Size	øCD	L	FL	XD+	MR	E	EW
L-41-32	32	10	13	22	212	10	46	26
L-41-40	40	12	16	25	246	12	52	28
L-41-50	50	12	16	27	286	12	64	32
L-41-63	63	16	21	32	324,5	16	74	40
L-41-80	80	16	22	36	373	16	93	50
L-41-100	100	20	27	41	401	20	112	60

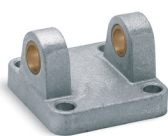
Rear female trunnion Mod. C

Material:
aluminium

Supplied with:
1x female trunnion
4x screws

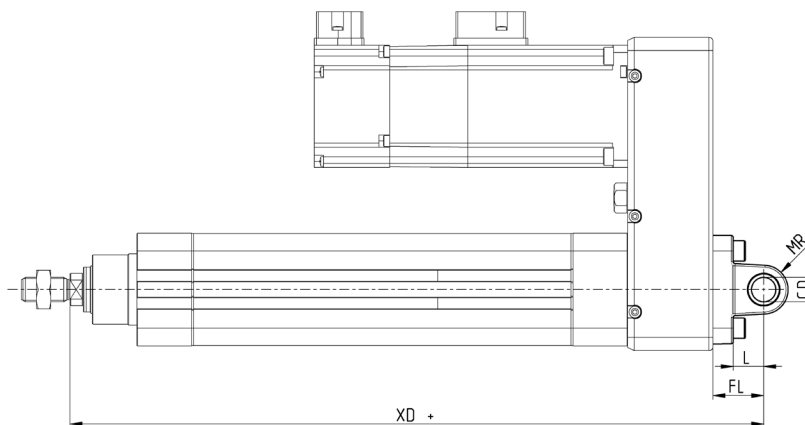
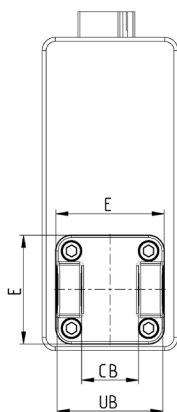

+ = add the stroke

Mod.	Size	øCD	L	FL	XD+	MR	E	CB	UB
C-41-32	32	10	13	22	212	10	46	26	45
C-41-40	40	12	16	25	246	12	52	28	52
C-41-50	50	12	16	27	286	12	64	32	60

Rear female trunnion Mod. C-H

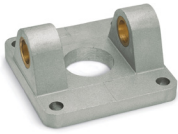

Material:
aluminium

Supplied with:
1x female trunnion
4x screws

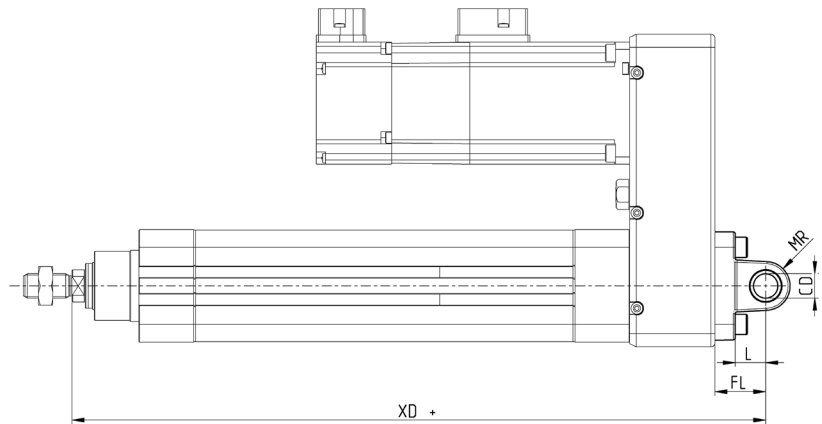
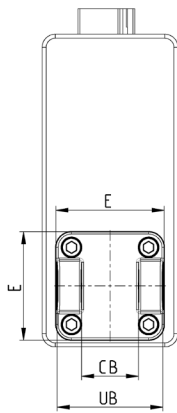

+ = add the stroke

Mod.	Size	\varnothing CD	L	FL	XD+	MR	E	CB	UB
C-H-41-63	63	16	21	32	324,5	16	74	40	70
C-H-41-80	80	16	22	36	373	16	93	50	90
C-H-41-100	100	20	27	41	401	20	112	60	110

Accessory combination Mod. C+L+S



Material:
aluminium

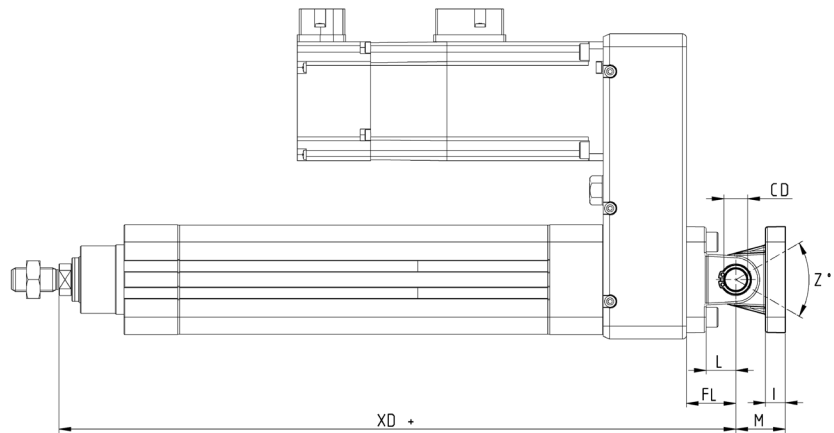
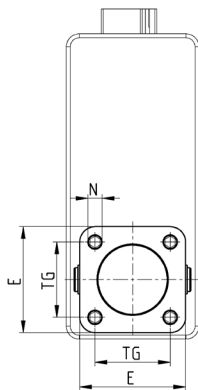

+ = add the stroke

Mod.	Size	E	TG	\varnothing N	XD+	\varnothing CD	L	FL	I	M	Z° (max)
C+L+S	32	46	32,5	6,5	212	10	13	22	13	22	30
C+L+S	40	52	38	6,5	246	12	16	25	16	25	40
C+L+S	50	64	46,5	9	286	12	16	27	16	27	25
C+L+S	63	74	56,5	9	324,5	16	21	32	21	32	36
C+L+S	80	93	72	11	373	16	22	36	22	36	34
C+L+S	100	112	89	11	401	20	27	41	27	41	38

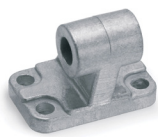
ELECTROMECHANICAL CYLINDERS
SERIES 6E - ACCESSORIES
90° male trunnion Mod. ZC

CETOP RP 107P

Material:
aluminium

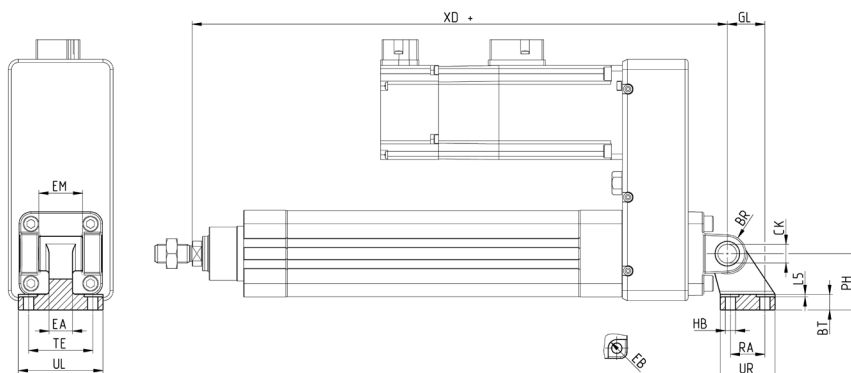
Supplied with:
1x male support



+ = add the stroke

Mod.	Size	EB	CK	HB	XD	TE	UL	EA	GL	L5	RA	EM	UR	PH	BT	BR
ZC-32	32	11	10	6,6	212	38	51	10	21	1,6	18	26	31	32	8	10
ZC-40	40	11	12	6,6	246	41	54	15	24	1,6	22	28	35	36	10	11
ZC-50	50	15	12	9	286	50	65	16	33	1,6	30	32	45	45	12	13
ZC-63	63	15	16	9	324,5	52	67	16	37	1,6	35	40	50	50	14	15
ZC-80	80	18	16	11	373	66	86	20	47	2,5	40	50	60	63	14	15
ZC-100	100	18	20	11	401	76	96	20	55	2,5	50	60	70	71	17	19

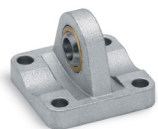
Trunnion ball-joint Mod. R

Material:
aluminium

Supplied with:
1x trunnion ball joint
4x screws

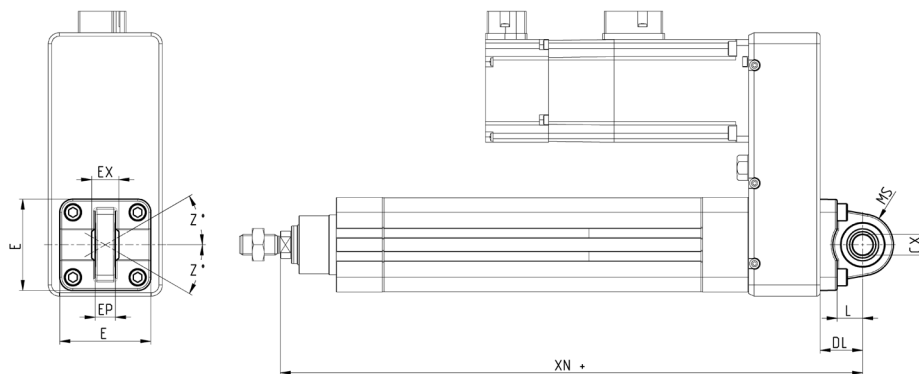

+ = add the stroke

Mod.	Size	CX	L	DL+	XN+	MS	E	EX	EP	Z
R-41-32	32	10	12	22	212	18	45	14	10.5	4°
R-41-40	40	12	15	25	246	18	53,5	16	12	4°
R-41-50	50	12*	15	27	286	21	62,5	16*	12*	4°
R-41-63	63	16	20	32	324,5	23	75	21	15	4°
R-41-80	80	16*	24	36	373	28	92	21*	15*	4°
R-41-100	100	20	29	41	401	30	115	25	18	4°
R-50	50	16	15	27	286	21	65	21	15	4°
R-80	80	20	20	36	373	28	95	25	18	4°

*This trunnion doesn't comply with the ISO 15552 standard

Clevis pin Mod. S



Materials:
Stainless steel Clevis pin,
Steel Seeger

Supplied with:
1x clevis pin
2x seeger in steel

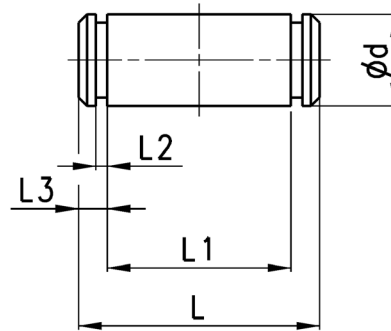

Mod.	Size	ϕD	L	L1	L2	L3
S-32	32	10	52	46	1,1	3
S-40	40	12	59	53	1,1	3
S-50	50	12	67	61	1,1	3
S-63	63	16	77	71	1,1	3
S-80	80	16	97	91	1,1	3
S-100	100	20	121	111	1,3	5

Swivel ball joint Mod. GA



ISO 8139

Material:
zinc-plated steel

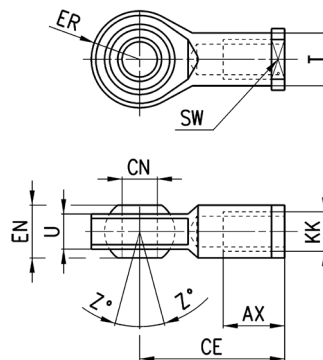

Mod.	ϕCN	U	EN	ER	AX	CE	KK	ϕT	Z	SW
GA-32	10	10,5	14	14	20	43	M10x1,25	15	6,5	17
GA-40	12	12	16	16	22	50	M12x1,25	17,5	6,5	19
GA-50-63	16	15	21	21	28	64	M16x1,5	22	7,5	22
GA-80-100	20	18	25	25	33	77	M20x1,5	27,5	7	30

Piston rod socket joint Mod. GY

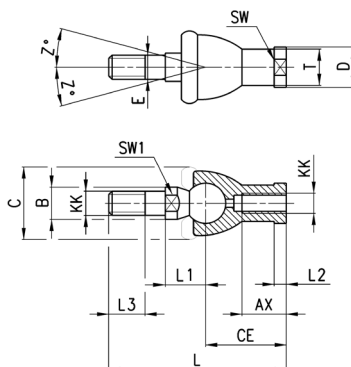

ISO 8139

 Material:
 zama and zinc-plated steel

Mod.	Size	KK	AX	CE	E	L	L1	L2	L3	SW	SW1	B	C	D	T	Z
GY-32	32	M10x1,25	18	35	10	74	19,5	6,5	15	17	11	14	28	19	15	15
GY-40	40	M12x1,25	20	40	12	84	21	6,5	17	19	17	19	32	22	17,5	15
GY-50-63	50-63	M16x1,5	27	50	16	112	27,5	8	23	22	19	22	40	27	22	11
GY-80-100	80-100	M20x1,5	38	63	20	133	31,5	10	25	30	24	27	45	34	27,5	7,5

Rod fork end Mod. G

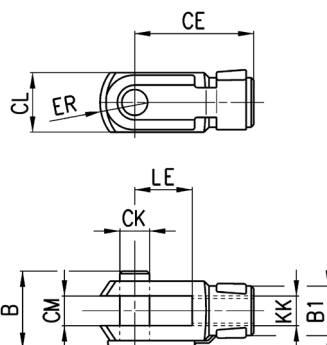

ISO 8140

 Material:
 zinc-plated steel

Mod.	ϕ CK	LE	CM	CL	ER	CE	KK	B	ϕ B1
G-25-32	10	20	10	20	12	40	M10x1,25	26	18
G-40	12	24	12	24	14	48	M12x1,25	32	20
G-50-63	16	32	16	32	19	64	M16x1,5	40	26
G-80-100	20	40	20	40	25	80	M20x1,5	48	34

Piston rod lock nut Mod. U

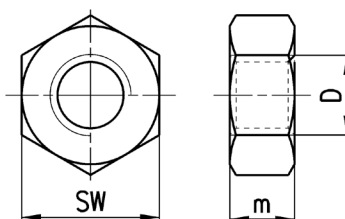
UNI EN ISO 4035

 Material:
 zinc-plated steel

Mod.	D	m	SW
U-25-32	M10x1,25	6	17
U-40	M12x1,25	7	19
U-50-63	M16x1,5	8	24
U-80-100	M20x1,5	9	30

Self aligning rod Mod. GK



Material:
zinc-plated steel

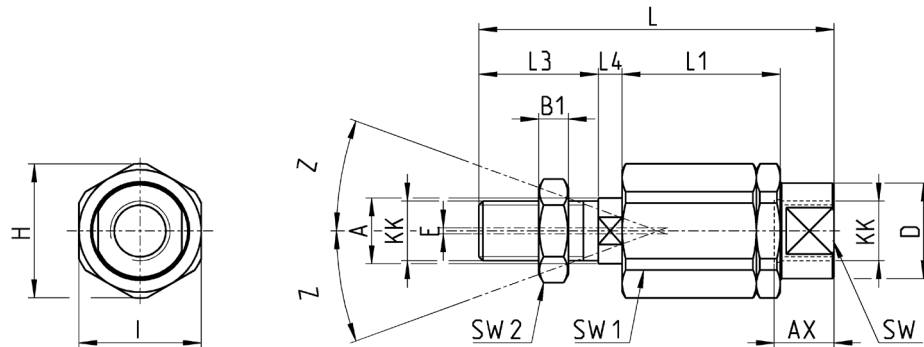

Mod.	Size	KK	L	L1	L3	L4	A	D	H	I	SW	SW1	SW2	B1	AX	Z	E
GK-25-32	32	M10x1,25	71,5	35	20	7,5	14	22	32	30	19	12	17	5	22	4	2
GK-40	40	M12x1,25	75,5	35	24	7,5	14	22	32	30	19	12	19	6	22	4	2
GK-50-63	50-63	M16x1,5	104	53	32	10	22	32	45	41	27	20	24	8	30	3	2
GK-80-100	80-100	M20x1,5	119	53	40	10	22	32	45	41	27	20	30	10	37	3	2

Coupling piece Mod. GKF



Material:
zinc-plated steel

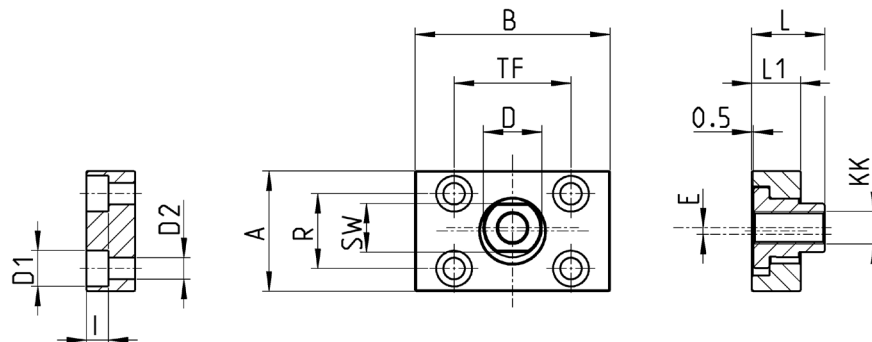

Mod.	Size	KK	A	B	R	TF	L	L1	I	D	D1	D2	SW	E
GKF-25-32	32	M10x1,25	37	60	23	36	22,5	15	6,8	18	11	6,6	15	2
GKF-40	40	M12x1,25	56	60	38	42	22,5	15	9	20	15	9	15	2,5
GKF-50-63	50-63	M16x1,5	80	80	58	58	26,5	15	10,5	25	18	11	22	2,5
GKF-80-100	80-100	M20x1,5	90	90	65	65	32,5	20	13	30,5	20	14	27	2,5

Slot cover profile Mod. S-CST-500

Supplied with 500 mm tube

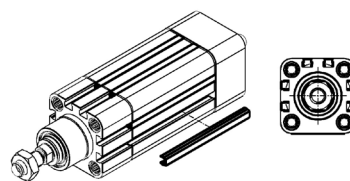

Mod.
S-CST-500

500

Slot nut for sensor Mod. PCV

Material: steel

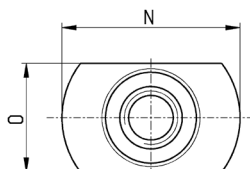
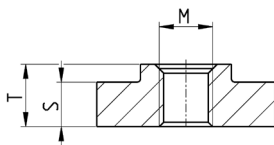
 Supplied with:
 2x nuts

Mod.	Size	M	N	O	S	T
PCV-5E-CS-M3	50 - 65 - 80	M3	10,3	6,1	2,5	3,5
PCV-5E-CS-M4	50 - 65 - 80	M4	10,3	6,1	2,5	3,5

GUIDE MOD. 45NUT, 45NHT, 45NHB

45	N	UT	050	A	0100
45	SERIES				
N	VERSION N = standard				
UT	OPERATION UT = "U" self lubricating guide HT = "H" self lubricating guide HB = "H" ball guide				
050	SIZE 032 = 32 040 = 40 050 = 50 063 = 63				
A	MATERIALS A = anodized aluminium body - stainless steel AISI 420B columns for 45UT and 45HT - hardened steel C50 columns for 45HB				
0100	STROKE in mm				

45NUT GUIDES - Applicable loads depending on projection

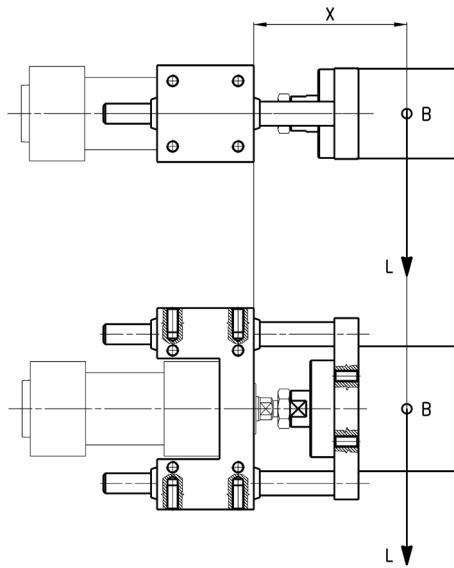

B = centre of gravity for applied load
L = load
X = fixed projection + stroke
 fixed projection = distance to the centre of gravity

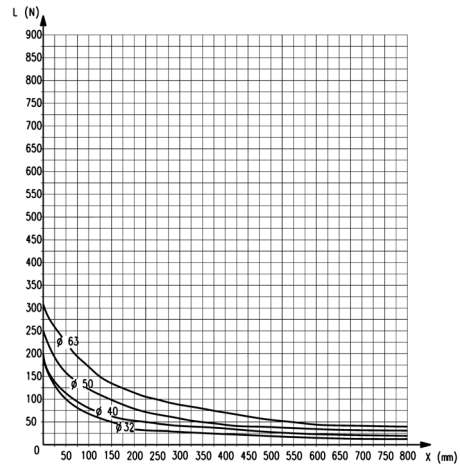

Guide "U" moving on bush (45NUT)

45NHB GUIDES - Applicable loads depending on projection

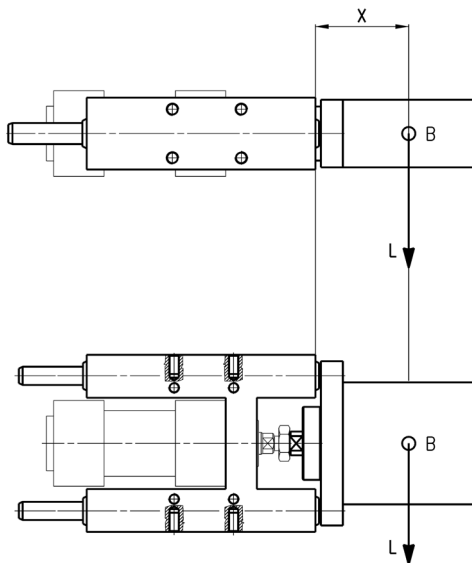

B = centre of gravity for applied load
L = load
X = fixed projection + stroke
 fixed projection = distance to the centre of gravity

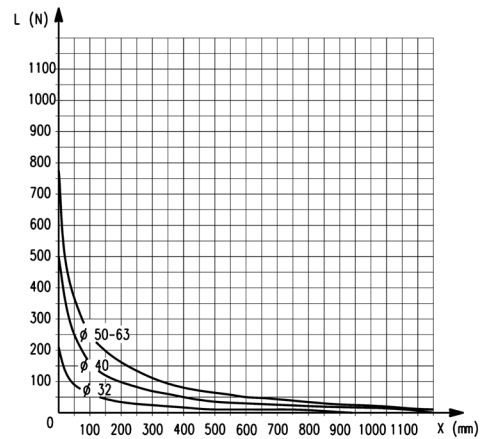

Guide "HB" with linear ball bearing (45NHB)

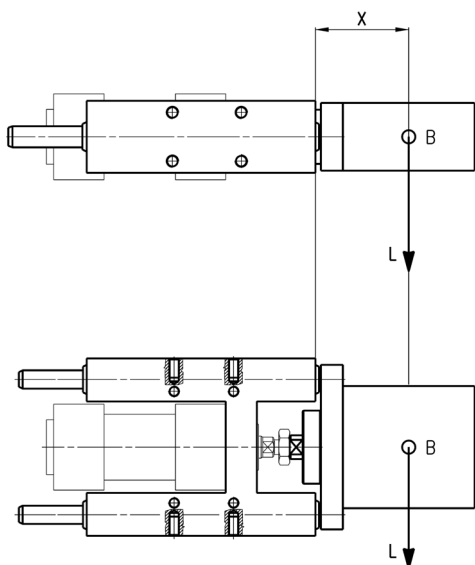
45NHT GUIDES - Applicable loads depending on projection

B = centre of gravity for applied load
L = load
X = fixed projection + stroke
 fixed projection = distance to the centre of gravity

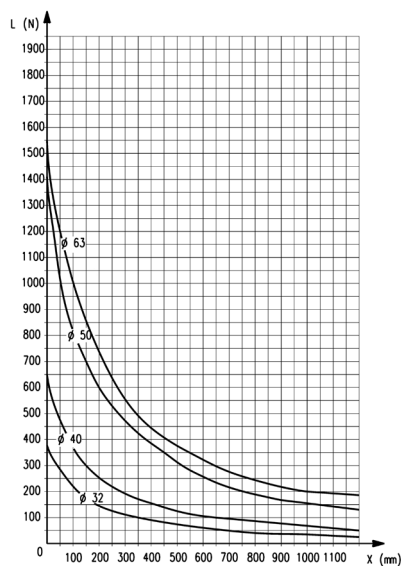

Guide "HT" moving on bush (45NHT)

Guides Mod. 45NHT for cylinders Series 6E

Material body:
 anodized aluminium
Coupling:
 stainless steel AISI 303

Supplied with:
 4x fixing screws

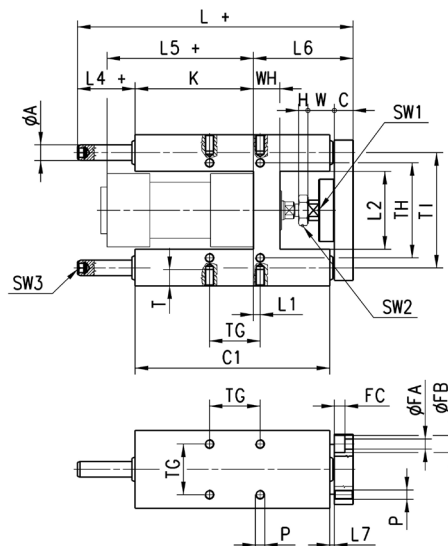
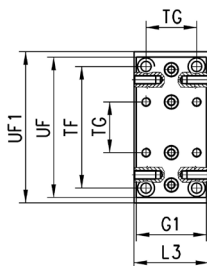

+ = add the stroke

Ø	TF	TG	TH	TI	UF	G1	UF1	gA	WH	C1	H	W	C	K	L	L1	L2	L3	L4	L5	L6	L7	P	T	gFA	gFB	FC	SW1	SW2	SW3
32	78	32,5	61	74	90	45	97	12	17	125	6	17	12	76	177	4,3	50,2	50	37	94	64	3	M6	14	6,5	11	6,8	13	17	6
40	84	38	69	87	110	54	115	16	21	140	7	22	12	81	192	11	58,2	58	37	105	74	3	M6	14	6,5	11	6,8	15	19	6
50	100	46,5	85	104	130	63	137	20	26	149	8	26	15	78,5	205	19,8	70,2	70	37,5	106	89	3	M8	16	9	15	9	22	24	6
63	105	56,5	100	119	145	80	152	20	26	178	8	26	15	111	237	15,3	85,2	85	37	121	89	7	M8	16	9	15	9	22	24	6

Guides Mod. 45NUT for cylinders Series 6E



Material body:
 anodized aluminium
Coupling:
 stainless steel AISI 303

Supplied with:
 4x fixing screws

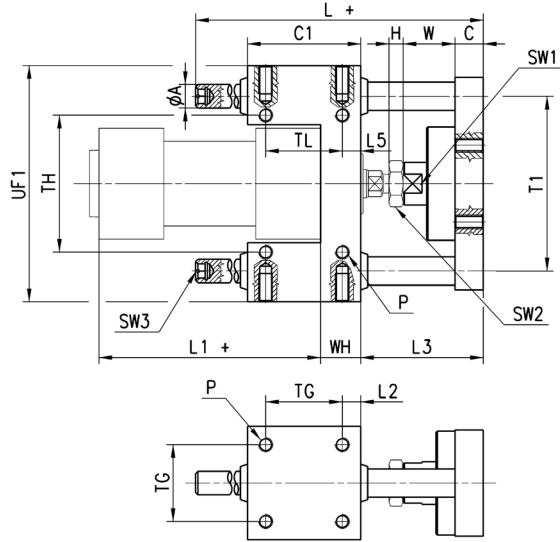
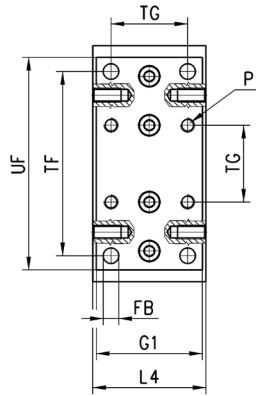

+ = add the stroke

Ø	TF	TG	TH	gA	T1	P	gFB	UF	G1	UF1	L	C1	H	W	C	L1	WH	L2	L3	L4	L5	TL	SW1	SW2	SW3
32	78	32,5	58	12	74	M6	6,6	90	45	100	106	48	6	22	12	94	17	7,8	52	48	7,8	32,5	15	17	6
40	84	38	64	12	80	M6	6,6	100	50	106	117	58	7	22	12	105	21	10	53	56	10	38	15	19	6
50	100	46,5	80	16	96	M8	9	120	60	125	129	59	8	26	15	106	25	6,2	64	66	6,3	46,5	22	24	6
63	105	56,5	95	16	104	M8	9	125	70	132	146	76	8	26	15	121	25	9,8	64	76	9,8	56,5	22	24	6

Guides Mod. 45NHB for cylinders Series 6E



Material body:
 anodized aluminium
Coupling:
 stainless steel AISI 303

Supplied with:
 4x fixing screws

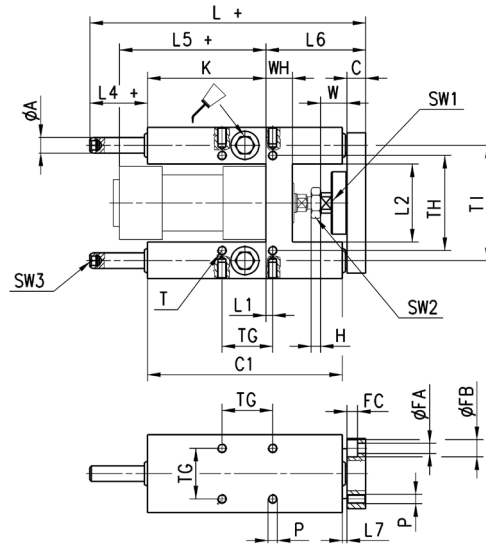
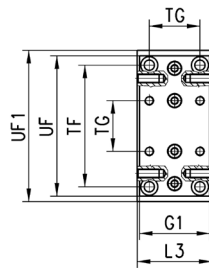

+ = add the stroke

Ø	TF	TG	TH	T1	UF	G1	UF1	gA	WH	C1	H	W	C	K	L	L1	L2	L3	L4	L5	L6	L7	P	T	gFA	gFB	FC	SW1	SW2	SW3
32	78	32,5	61	74	90	45	97	12	17	125	6	17	12	76	177	4,3	50,2	50	37	94	64	3	M6	14	6,5	11	6,8	13	17	6
40	84	38	69	87	110	54	115	16	21	140	7	22	12	81	192	11	58,2	58	37	105	74	3	M6	14	6,5	11	6,8	15	19	6
50	100	46,5	85	104	130	63	137	20	26	149	8	26	15	78,5	237	19,8	70,2	70	69,5	106	89	3	M8	16	9	15	9	22	24	6
63	105	56,5	100	119	145	80	152	20	26	178	8	26	15	111	237	15,3	85,2	85	37	121	89	7	M8	16	9	15	9	22	24	6

Guide MOD. 6ENHT

6EN	HT	080	A	0100
6EN	MODEL			
HT	OPERATION HT = "H" self lubricating guide			
080	BORE 080 = 80 100 = 100			
A	MATERIALS A = anodized aluminium body - stainless steel AISI 420B columns for 45UT and 45HT - hardened steel C50 columns for 45HB			
0100	STROKE in mm			

ELECTRIC ACTUATION

2

6ENHT GUIDES - Applicable loads depending on projection

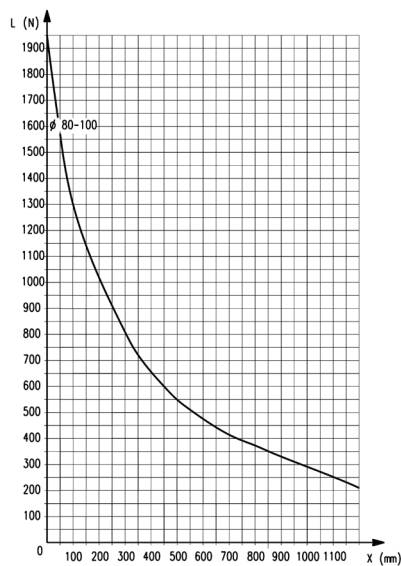
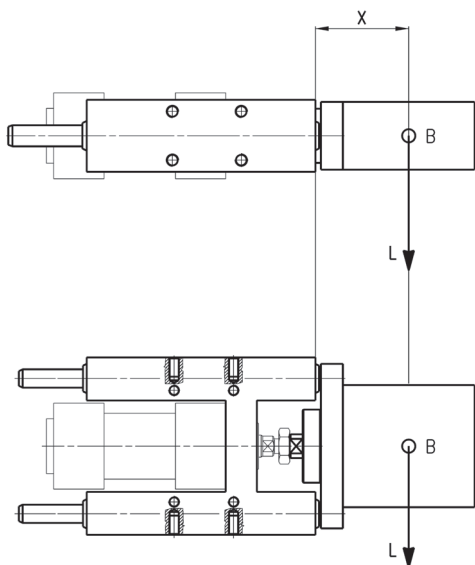

B = centre of gravity for applied load
L = load
X = fixed projection + stroke
fixed projection = distance to the centre of gravity

Guide "HT" moving on bush (45NHT)

Guides Mod. 6ENHT



Material Body:
anodized aluminium
Coupling:
stainless steel AISI 303

Supplied with:
4x fixing screws

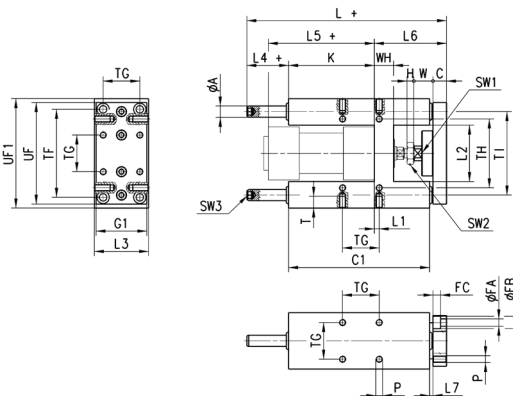

+ = add the stroke

Ø	TF	TG	TH	TI	UF	G1	UF1	ØA	WH	C1	H	W	C	K	L	L1	L2	L3	L4	L5	L6	L7	P	T	ØFA	ØFB	FC	SW1	SW2	SW3
80	130	72	130	148	180	100	189	25	34	195	9	32	20	128	280	21	105,4	105	42	128	110	23	M10	20	11	18	11	27	30	6
100	150	89	150	172	200	120	213	25	39	220	9	32	20	128	280	24,5	130,4	130	37	138	115	3	M10	20	11	18	11	27	30	6